

2000 Sterling

onderlopend rechtschuivend beslag

Rail:

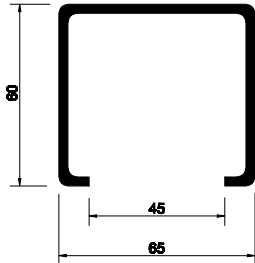

Model: 13

Materiaal: stalen buisprofiel, gegalvaniseerd volgens sendzimir procédé.

Langtes: 2000, 2500 en 3000mm

Bevestigingsgaten: geen

Raildragers - wandbevestiging:

RAILDRAGER 1/13

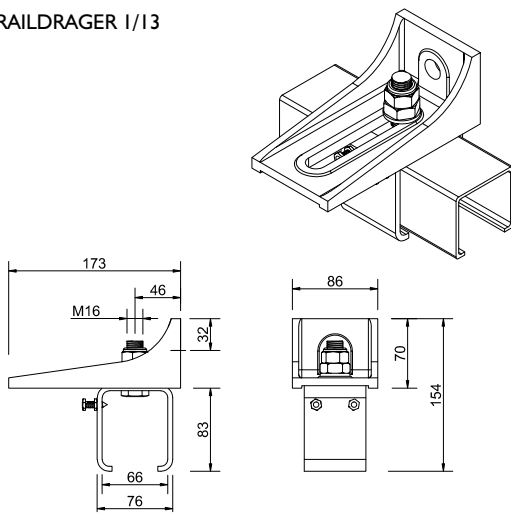

RAILDRAGER 5/13

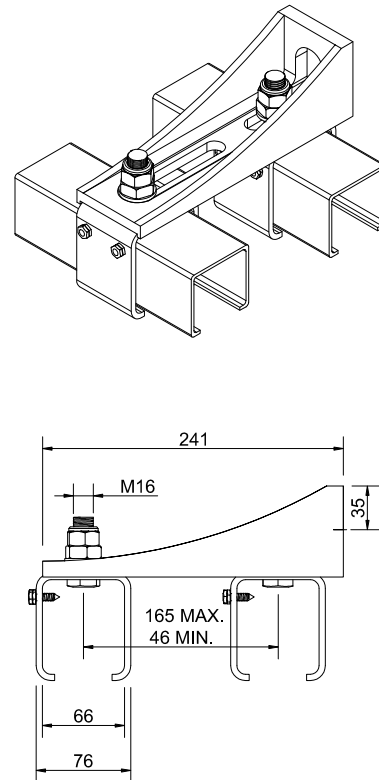

Raildragers - plafondbevestiging:

RAILDRAGER 2/13

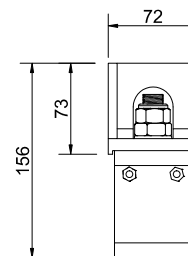
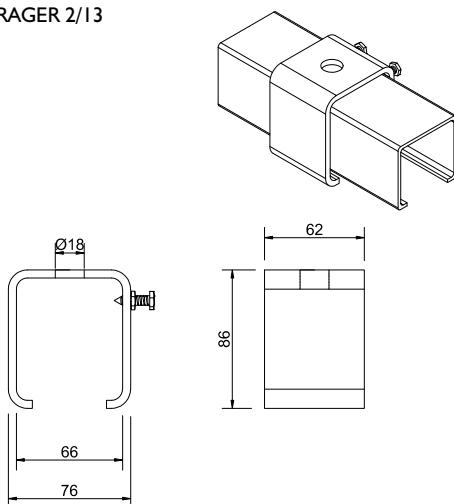

Legenda:



= Houten deur



= Staal



= Stalen wielen



= Stalen deur



= Stalen geleidewiel

2000

2000 Sterling

onderlopend rechtschuivend beslag

Bovengeleiders:

BOVENGELEIDER 53/13

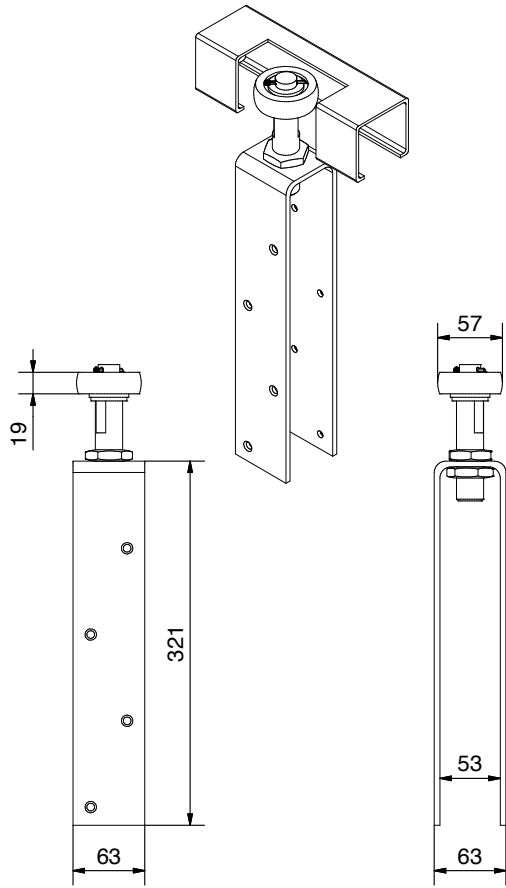

BOVENGELEIDER 104/13

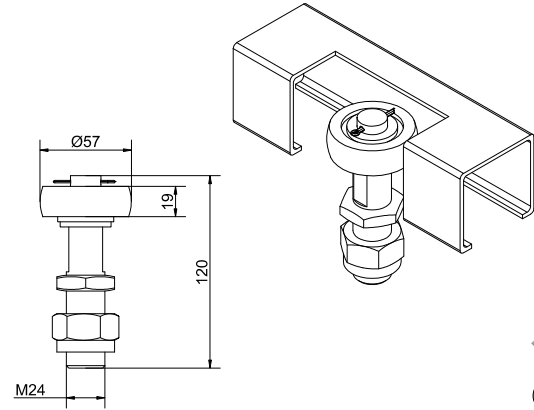

Onderrails:

ONDERRAIL 298

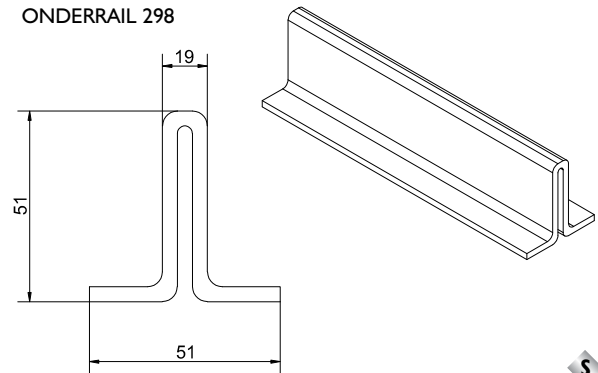

Onderrollen:

ONDERROL 4J

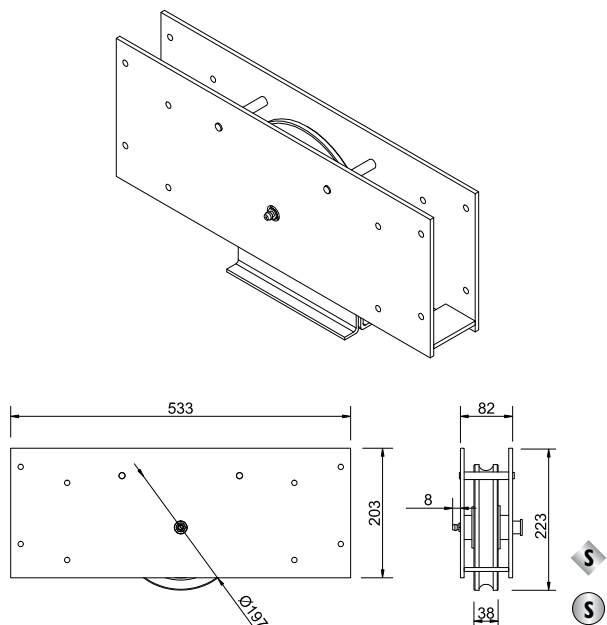

ONDERROL 4SJ

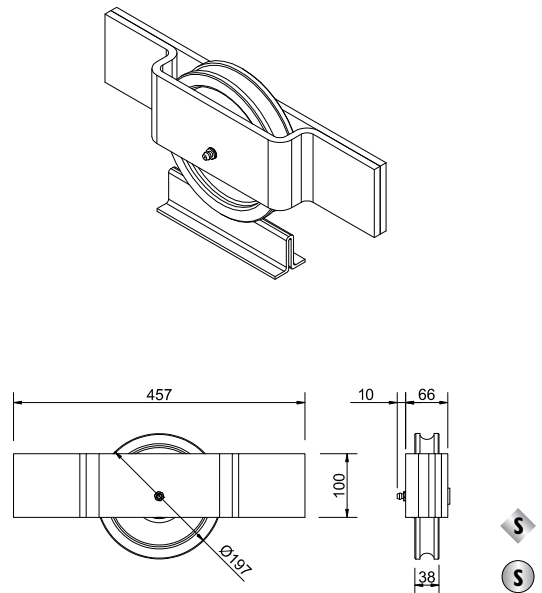

2000

2000 Sterling

onderlopend rechtschuivend beslag

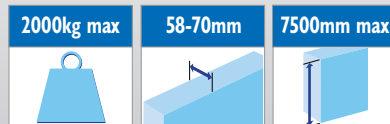

Stelsel opstelling: enkele rail

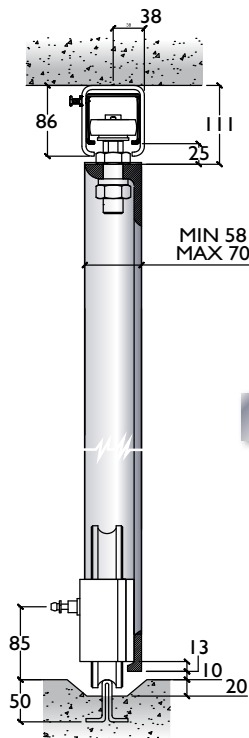
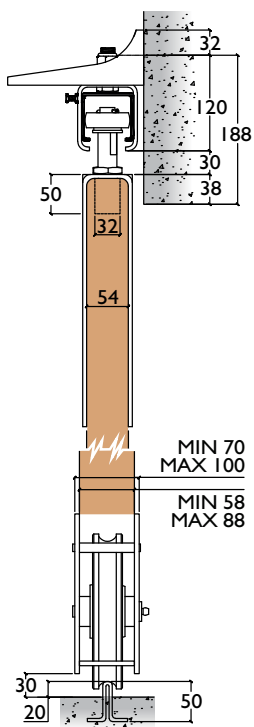
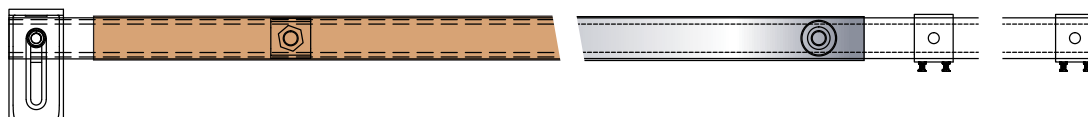
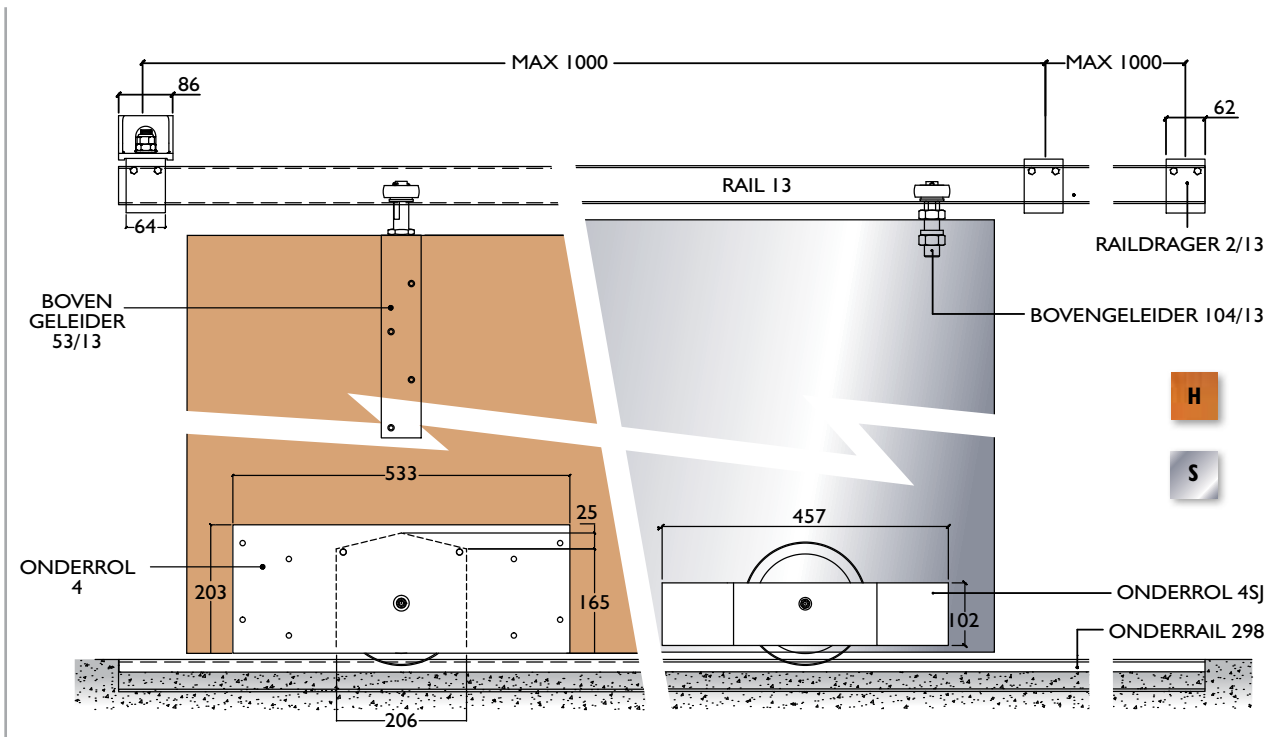

Opmerking:

Het gewicht van de deur(en) wordt door de vloer gedragen, zodat een lichte bovenconstructie mogelijk is.

Elk willekeurig aantal deuren kan worden toegepast op enkele of meervoudige railbanen.

De bovengeleiderail kan tegen de onderzijde van de bovendorpel van het kozijn worden gemonteerd, indien de deur in de dagopening schuift of tegen de zijwand als de deur geheel moet wegschuiven.

Hoge onderdorpels zijn noodzakelijk (minimaal 300mm) om de onderrollen te kunnen inbouwen.

2000