

# System 305

## universele onderdelen

Rail:

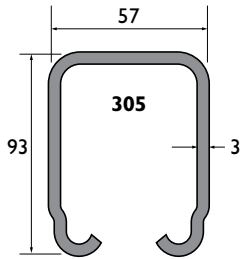

**Model:** 305

**Materiaal:** koudgewalst staal, gegalvaniseerd volgens sendzimir procédé

**Lengtes:** 2000, 3000, 4000, 5000 en 6000mm

**Bevestigingsgaten:** geen

305

Raildragers - wandbevestiging:

RAILDRAGER 1A/305  
RAILDRAGER 1A/305LC  
RAILDRAGER 1A/305RC

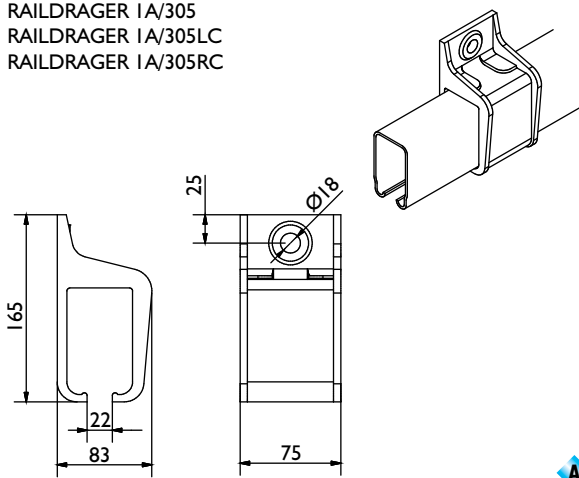

RAILDRAGER 5A/305  
RAILDRAGER 5A/305LC  
RAILDRAGER 5A/305RC

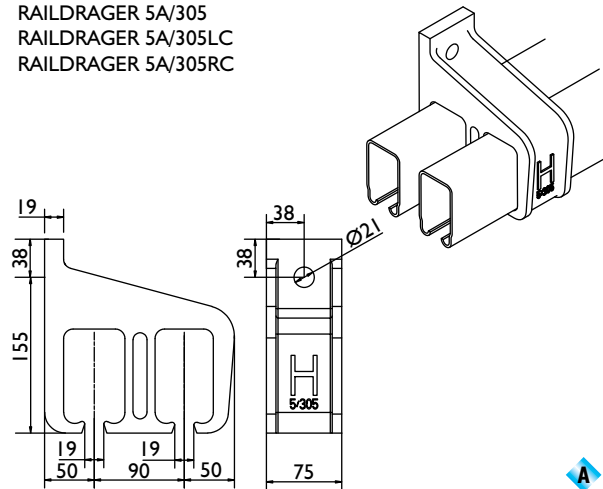

RAILDRAGER 9A/305  
RAILDRAGER 9A/305LC  
RAILDRAGER 9A/305RC

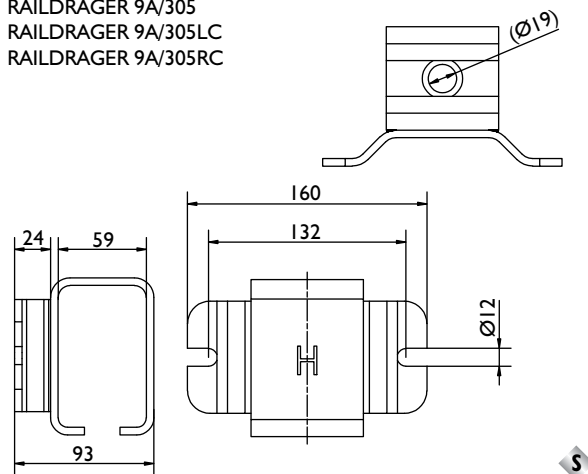

Legenda:

**H** = Houten deur

**S** = Stalen deur

**S** = Staal

**A** = Aluminium

**S** = Stalen wielen

**N** = Nylon wielen

**Opmerking:**

Verbindings-raildragers worden aanbevolen op elke railverbinding. Bij het specificeren de letter "X" toevoegen.

Toevoeging **C** = gesloten raildrager  
Toevoeging **LC** = links gesloten raildrager  
Toevoeging **RC** = rechts gesloten raildrager

Gesloten raildragers dienen aan beide einden van de totale railbaan te worden gemonteerd en dienen uitsluitend voor het afsluiten van de rail, niet als deurbuffer gebruiken.

# System 305

## universele onderdelen

### Raildragers - plafondbevestiging:

RAILDRAGER 3A/305  
RAILDRAGER 3A/305C

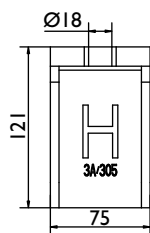
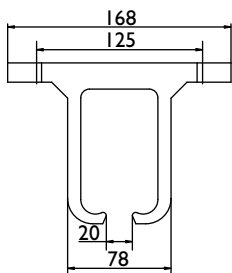
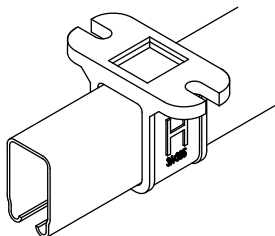

RAILDRAGER 4A/305  
RAILDRAGER 4A/305C

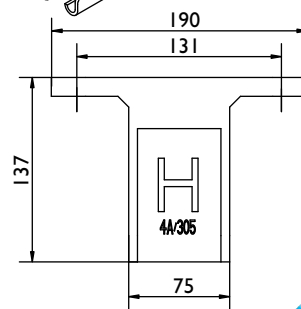
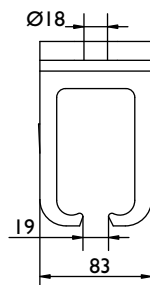
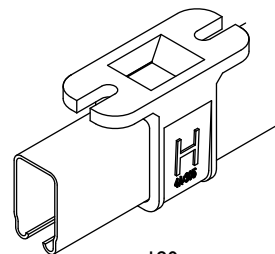

RAILDRAGER 4R/305  
RAILDRAGER 4R/305SC

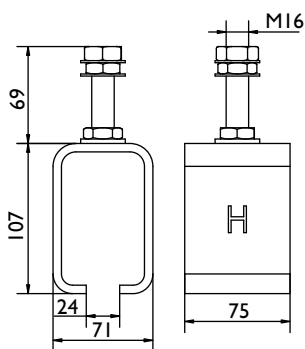
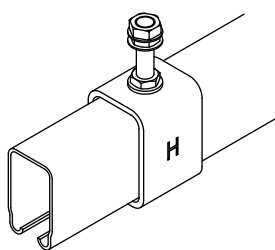

LASDRAGER 4R/305SB

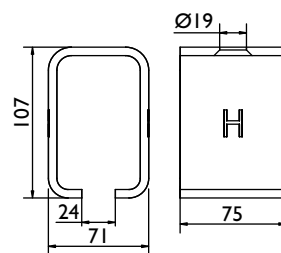
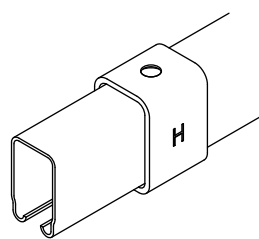

### Specials:

STOP 107

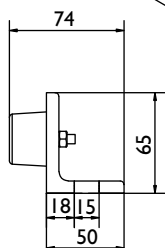
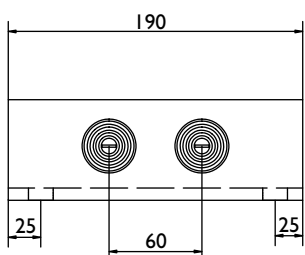
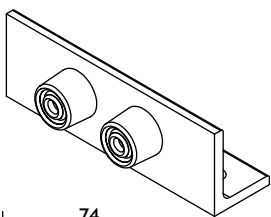

STOP 109

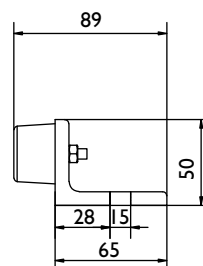
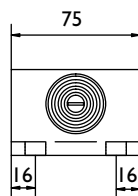
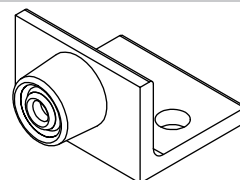

# System 305

## tangent vouwdeurbeslag

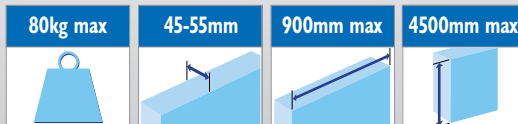

### System opstelling:

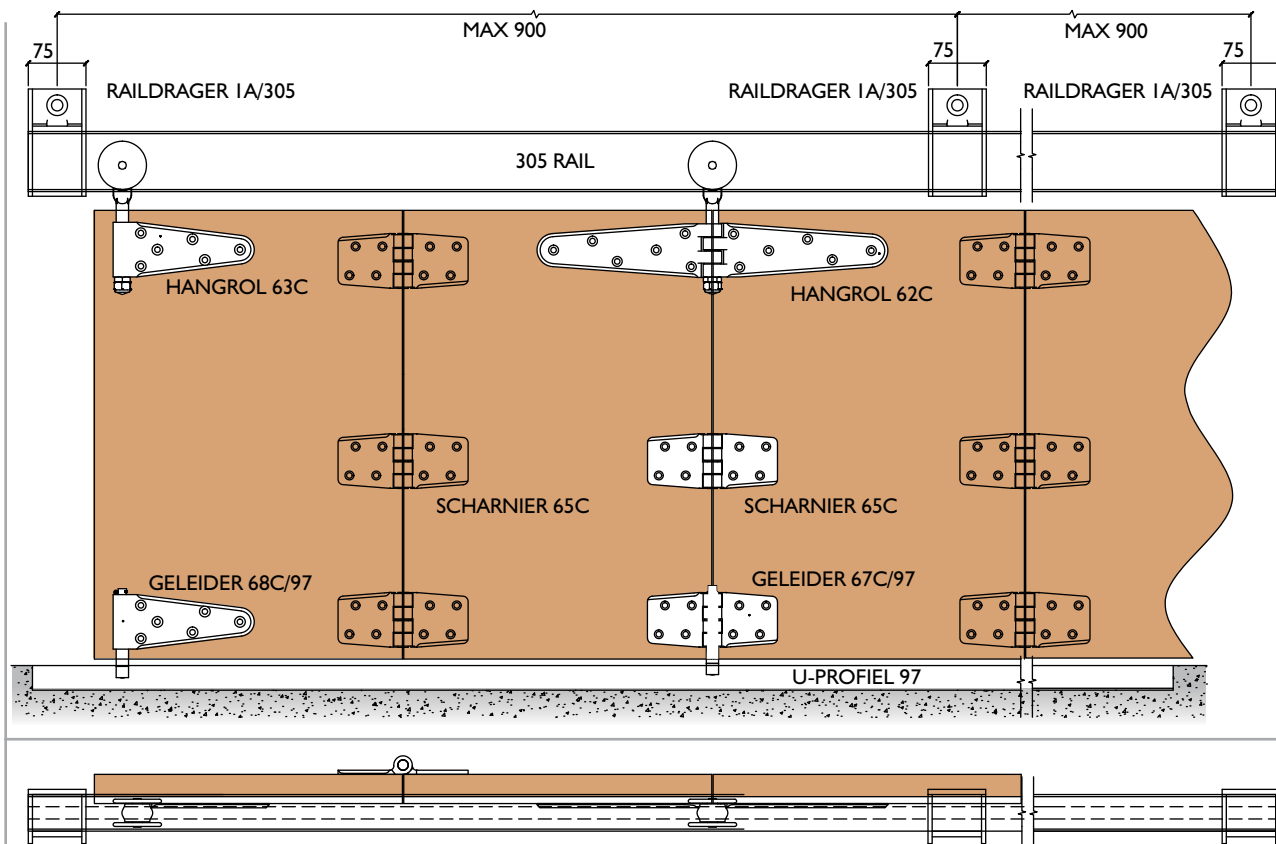

305

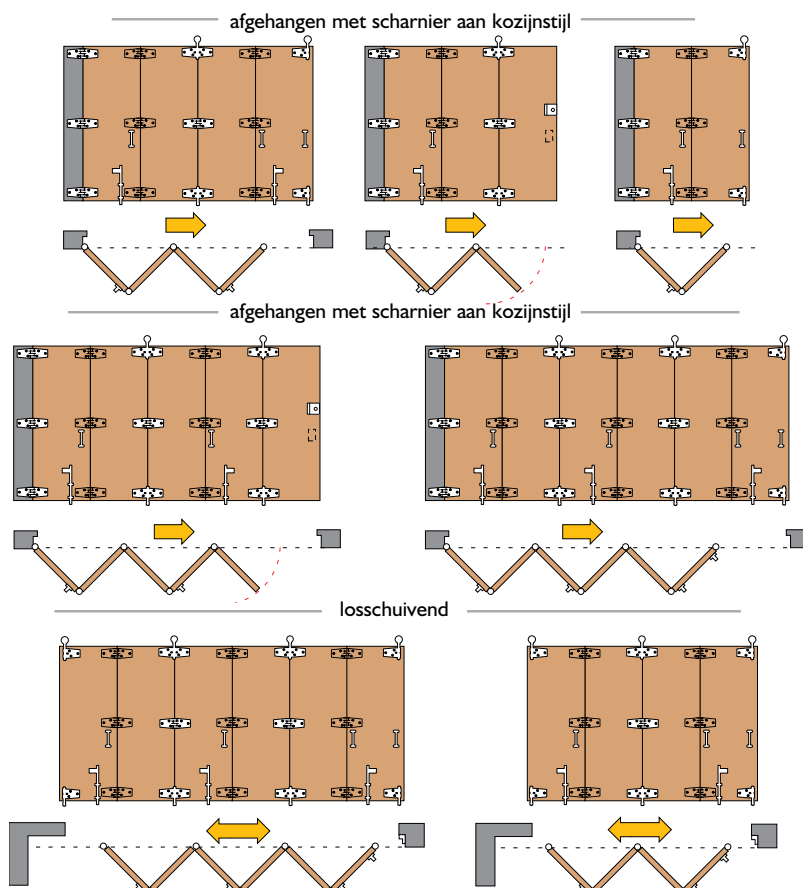
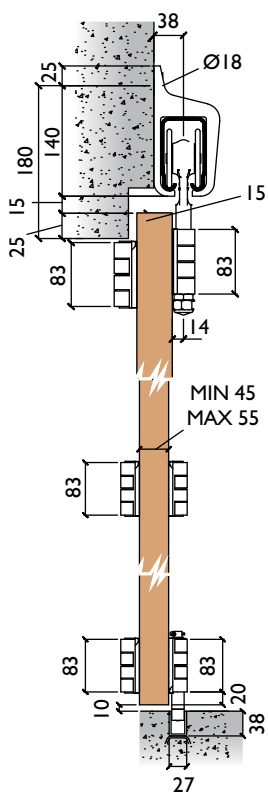

# System 305

## tangent vouwdeurbeslag

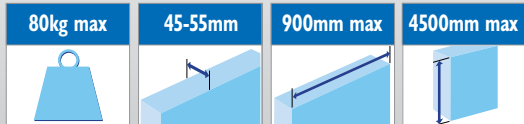

### Hangrollen, geleiders en scharnieren:

HANGROL 62C

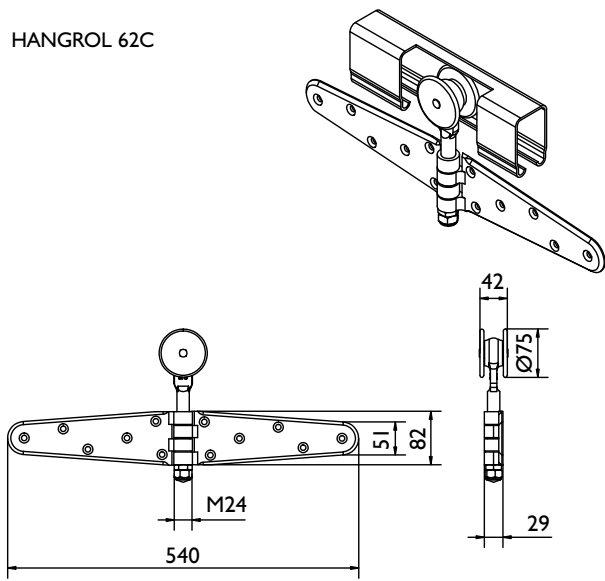

HANGROL 63C

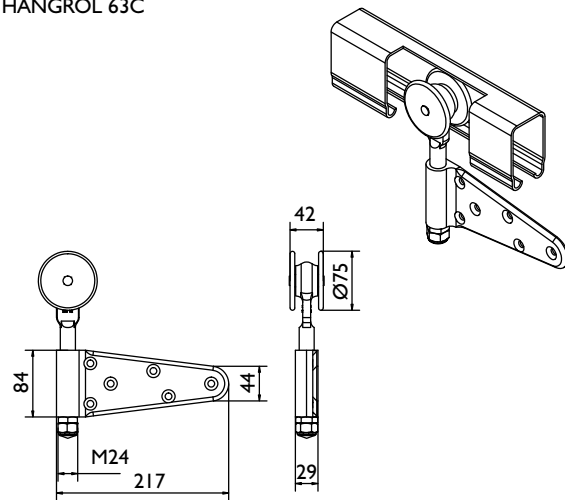

GELEIDER 67C/97

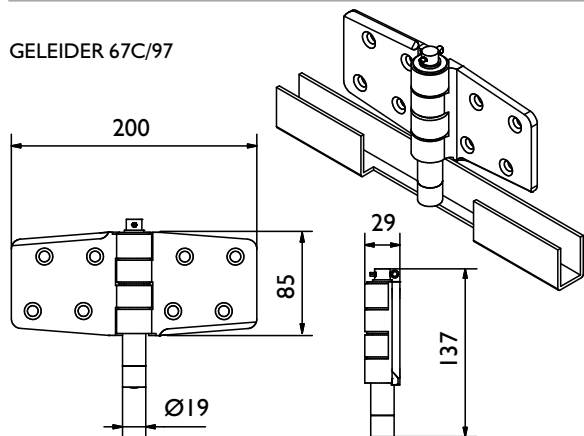

GELEIDER 68C/97

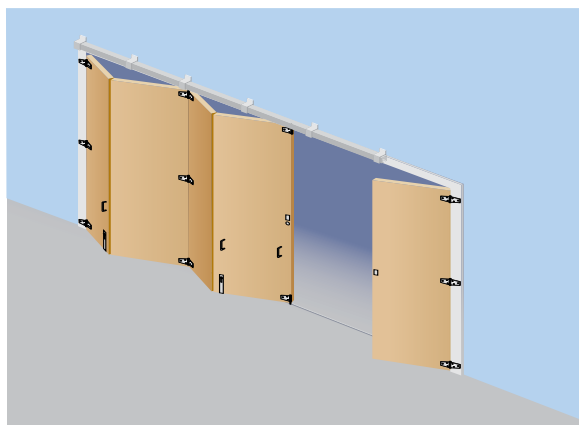
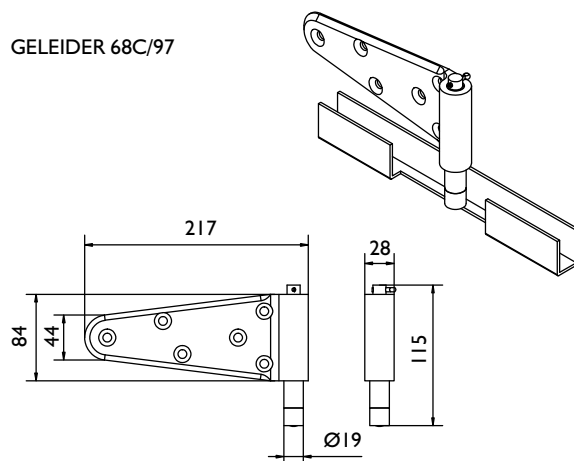

SCHARNIER 65C

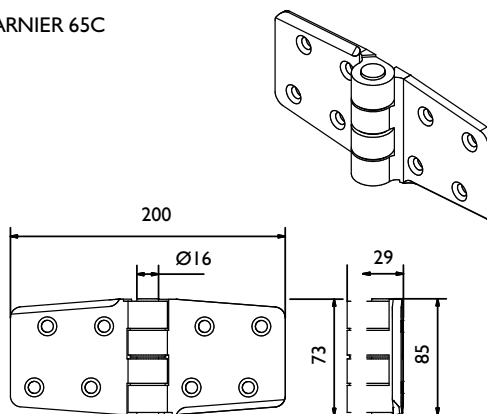

### Opmerking:

H.o.h. afstanden scharnierpunten dienen gelijk te zijn!

Op de plaats waar het samengevouwen deurpakket hangt, moet een extra raildrager gemonteerd zijn.

Voor een soepele werking maximaal acht deurvleugels ahangen, alternatief kunnen losschuivende garnituren worden toegepast (minimaal 4 deurvleugels).

Desgewenst kan van één van de deurvleugels, oneven aantal, een loopdeur worden gemaakt.