

PACER and HUSKY Glass Clamp Fixing Instructions

PACER

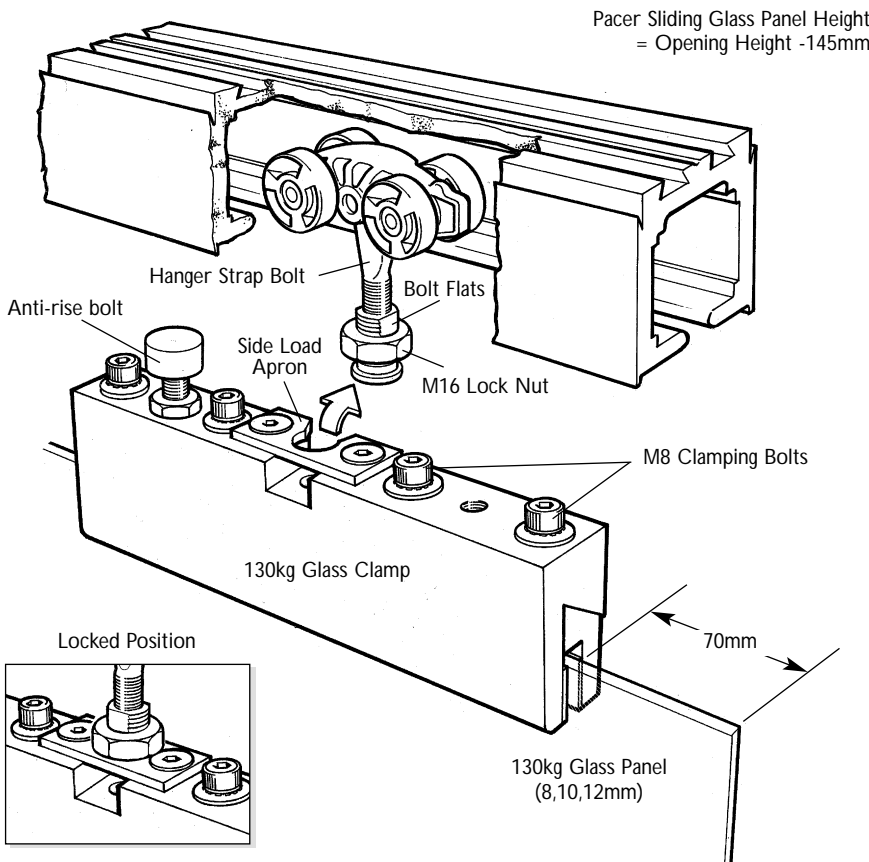

HUSKY

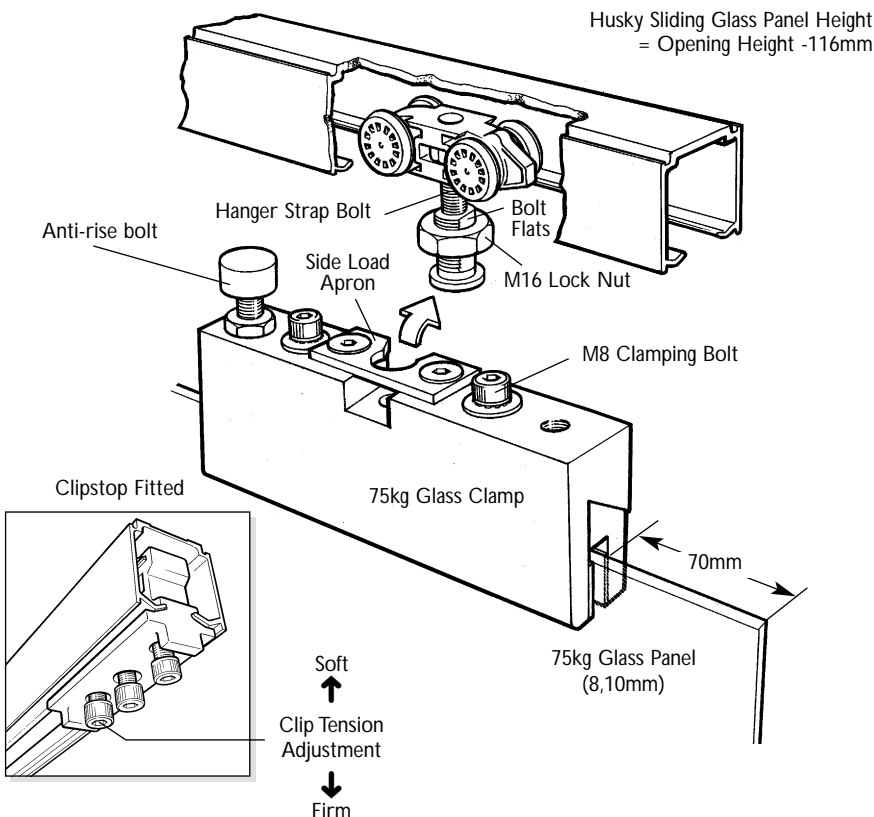

Glass Clamp Installation

1. Install the track with the hangers and clipstops in the track.
2. Attach the loosely assembled glass clamps to the glass panel, 70mm in from each end. For ease of installation have the apron plate slot facing towards the track and away from the installer. Ensure that there is 5mm clearance between the top of the glass panel and the bottom clamp profile. When the glass is fully located within the clamp and in the correct position tighten the M8x40 bolts to 25NM.

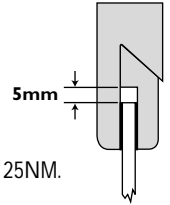

3. Where two nylon bottom glass guides are provided (8/10mm kits) select the correct guide for the glass thickness.



4. Locate and secure the bottom guide to the floor using the wood screws provided.
5. Position the hangers in the track the same distance apart as the glass clamps. Align the bolt flats of the hanger strap bolts with the glass clamp apron slots, then lift the glass panel onto the hanger strap bolts.
6. Adjust the glass panel height to the correct position by rotating the hanger strap bolts, adjust the anti-rise bolt.
7. Align the bolt flats to the line of the glass, then tighten the M16 lock nut.
8. Position the clip stops in the track so that they bring the hangers to a stop when the panel is in the desired position.

WARNING: When using glass clamps in combination with protective coatings for glass surfaces such as Clear Shield (manufactured by Ritec), ensure that the glass surface to be clamped is not treated with the Clear Shield coating.

Parts list

- 2 x Glass clamps
- 2 x Hangers (Pacer or Husky)
- 2 x Clip stops
- 1 x Guide (12mm kit)
- 2 x Guides (8 and 10mm kits)

Tools required

- Torque wrench 6mm attachment
- 13mm, 17mm and 24mm spanners
- Pozi drive screwdriver
- 5mm Allen key

HENDERSON

DURHAM ROAD, BOWBURN, CO. DURHAM, DH6 5NG, ENGLAND
 Tel: 44(0)191 3770701 Fax: 44(0)191 3770755
 e-mail: international@pchenderson.com
www.pchenderson.com