

FITTING INSTRUCTIONS - NOTICE DE POSE - MONTAGE HANDLEIDING - MONTAGEANLEITUNG INSTRUZIONI DI MONTAGGIO - INSTUCCIONES DE MONTAJE

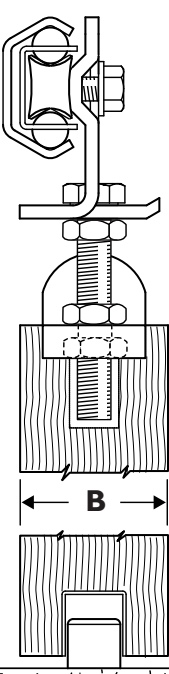

SYSTEM	WEIGHT kg	mm		
		A	B	C
S2	90kg	400-750	32-50	267
S3	90kg	750-900	32-50	368
S4	90kg	900-1050	32-50	445
S5	90kg	1050-1200	32-50	546
S6	90kg	1200-1500	32-50	724
S7	90kg	1500-1800	32-50	1003
S8	90kg	1800-2000	32-50	1003
S9	90kg	2000-2500	32-50	1764

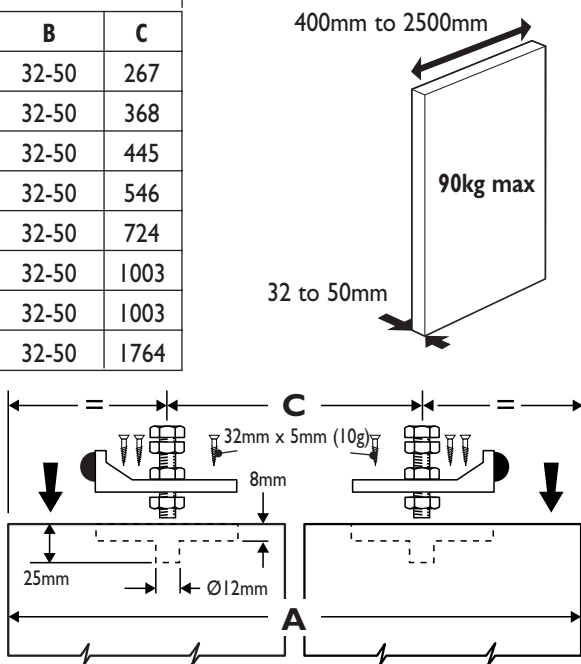

Diagram 1.

Systems S2/S3/S4 and S5
400 - 1200mm and up to 90kg

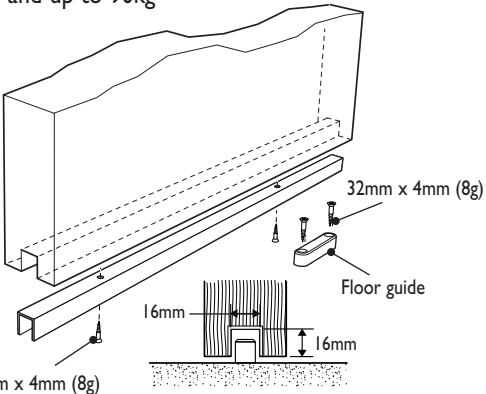

Diagram 2(a).

Systems S6/S7/S8 and S9
1200 - 2500mm and up to 90kg

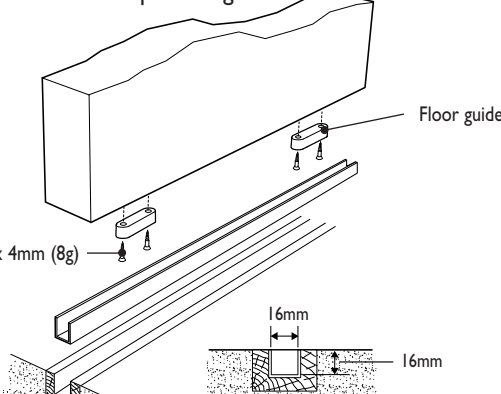

Diagram 2(b).

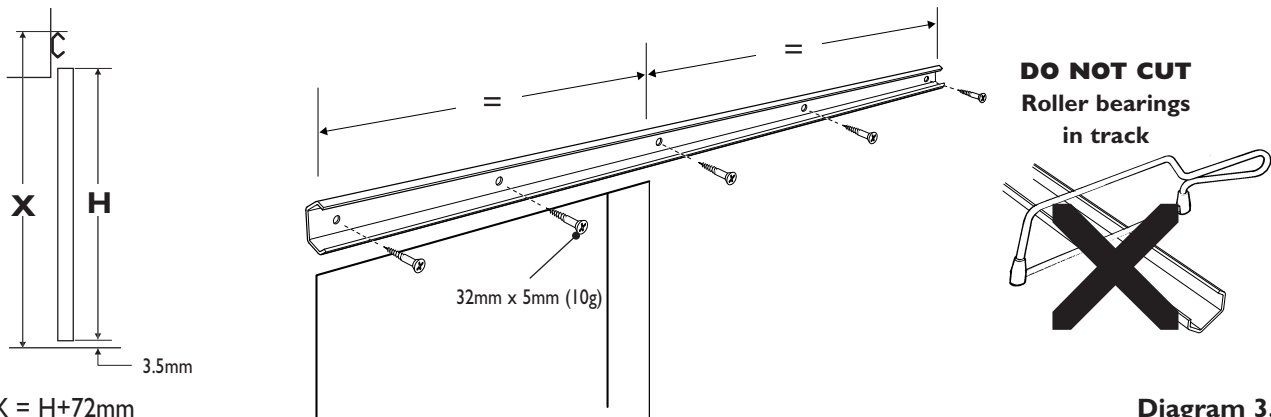

Diagram 3.

**DO NOT CUT
Roller bearings
in track**

$X = H + 72\text{mm}$

Diagram 4.

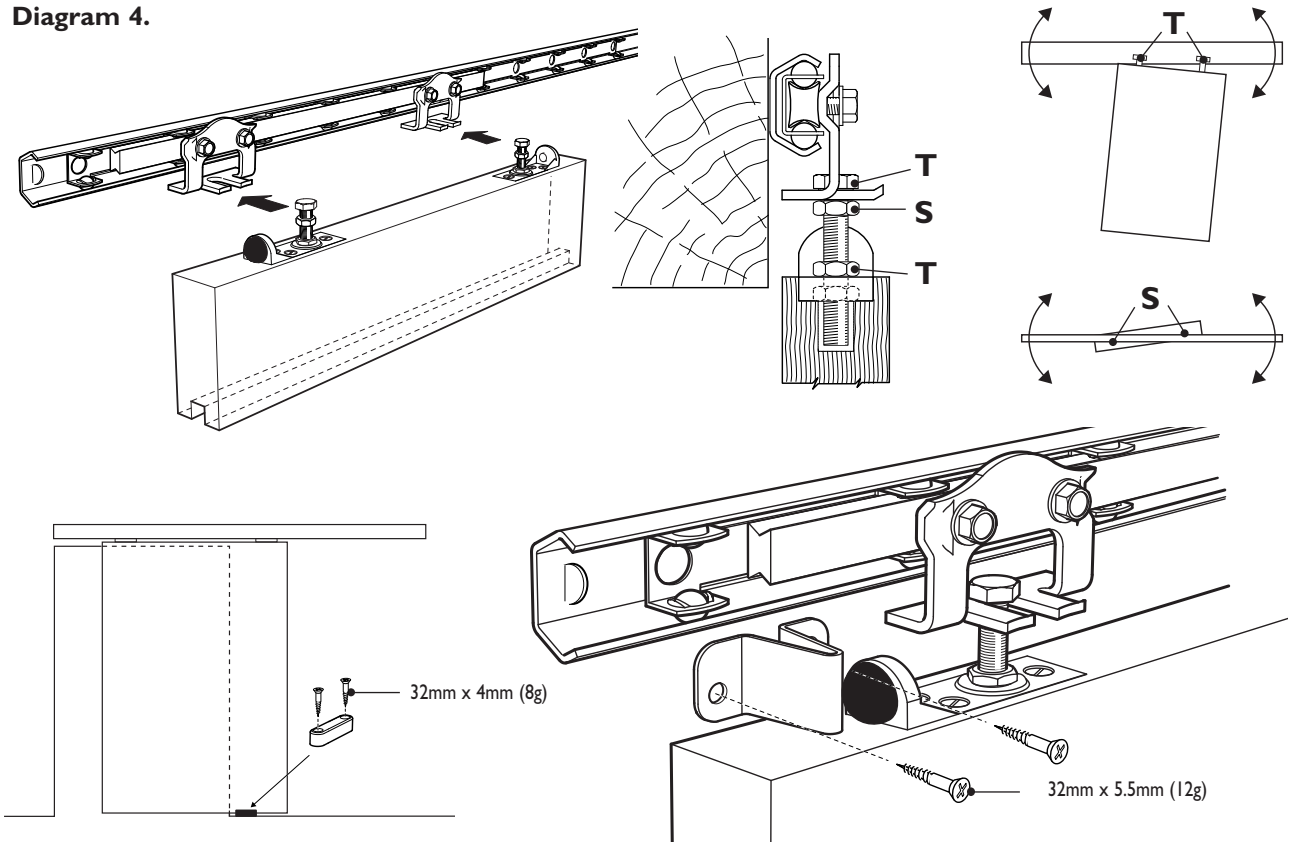
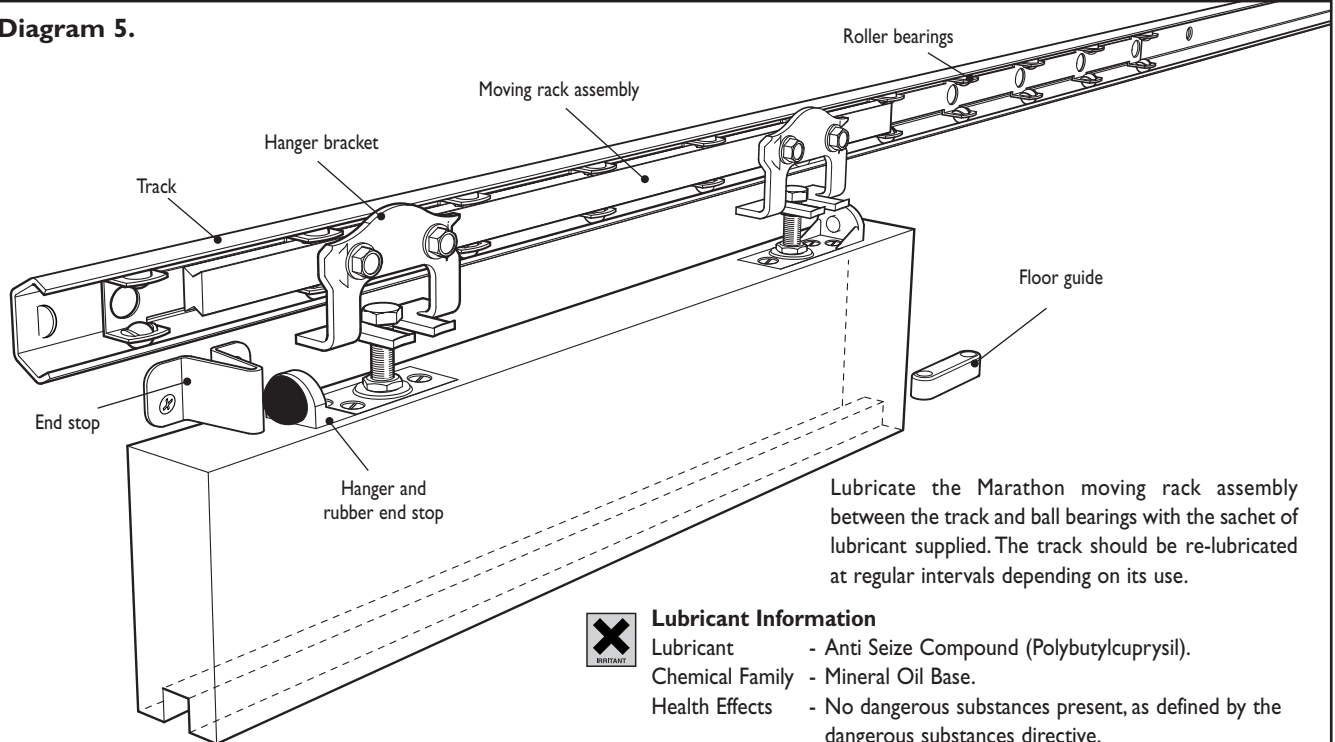

Diagram 5.



Lubricate the Marathon moving rack assembly between the track and ball bearings with the sachet of lubricant supplied. The track should be re-lubricated at regular intervals depending on its use.



Lubricant Information

- Lubricant - Anti Seize Compound (Polybutylcuprysil).
- Chemical Family - Mineral Oil Base.
- Health Effects - No dangerous substances present, as defined by the dangerous substances directive.
- First Aid - Eyes: Wash with water and consult medical practitioner.
- Skin: Wash with warm water and soap.
- Ingestion: Call medical practitioner immediately.



H411 Toxic to aquatic life with long lasting effects.
 P273 Avoid release to the environment.
 P391 Collect spillage.
 P501 Dispose of contents/container in accordance with local/regional/national/international regulations.

Please see website for Health & Safety datasheet.

