

225 Sterling

onderlopend rechtschuivend beslag

Rail:

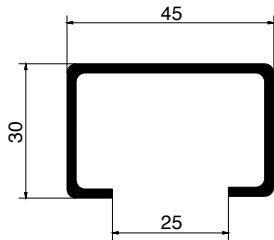

Model: 900

Materiaal: stalen buisprofiel, gegalvaniseerd volgens sendzimir procédé.

Langtes: 2000, 2500 en 3000mm

Bevestigingsgaten: geen

Raildragers - wandbevestiging:

RAILDRAGER 1/900

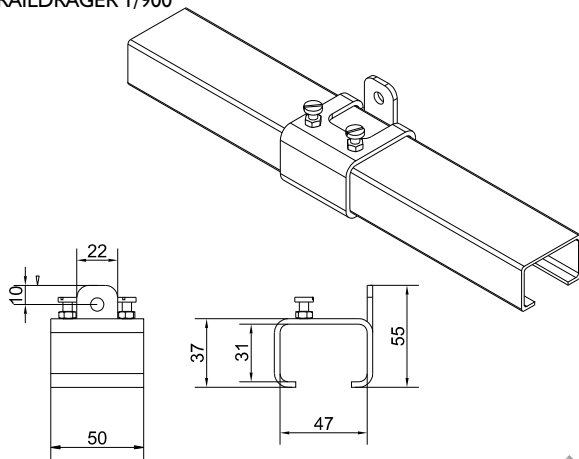

RAILDRAGER 5/900

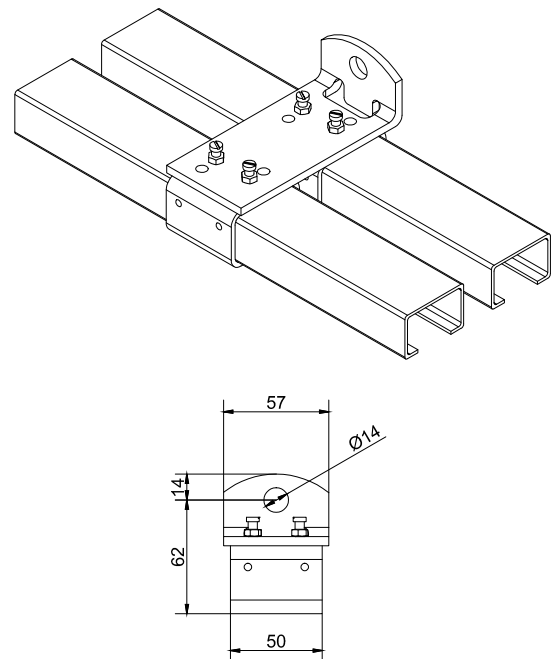

Raildragers - plafondbevestiging:

RAILDRAGER 3/900

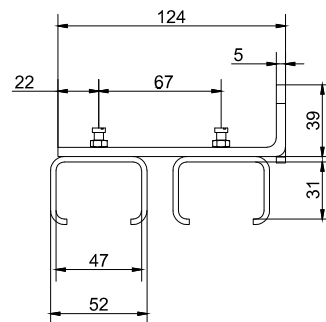
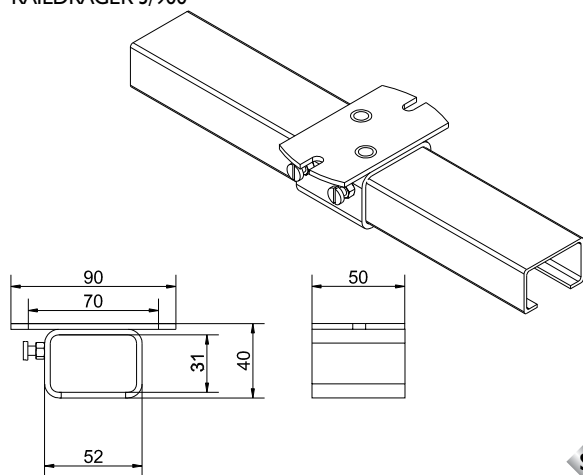

Legenda:



= Houten deur



= Staal



= Stalen wielen



= Stalen deur



= Nylon geleidewiel

225 Sterling

onderlopend rechtschuivend beslag

Bovengeleiders:

BOVENGELEIDER 54/900

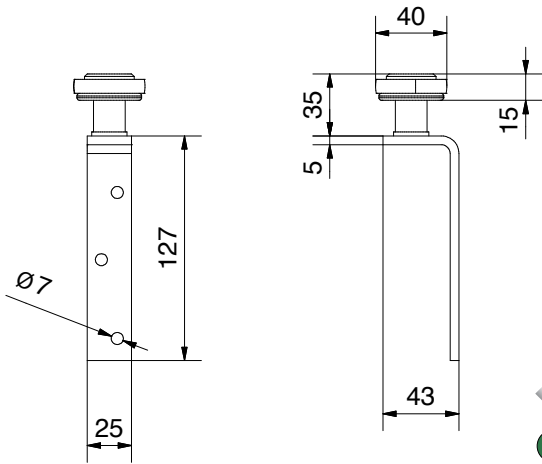
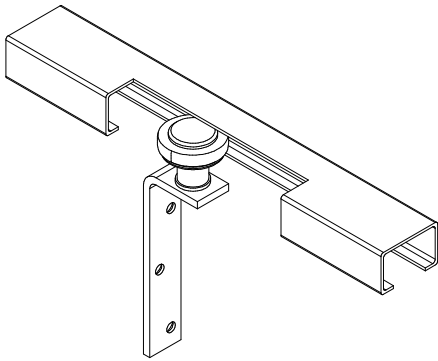

BOVENGELEIDER 104/900

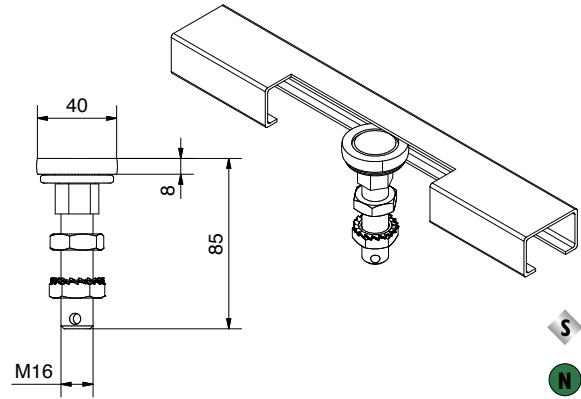

Onderrails:

ONDERRAIL 299

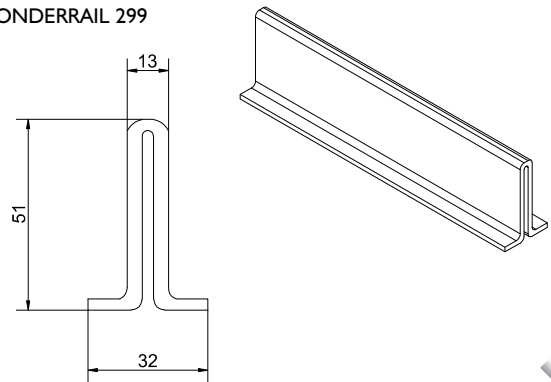

Onderrollen:

ONDERROL 5

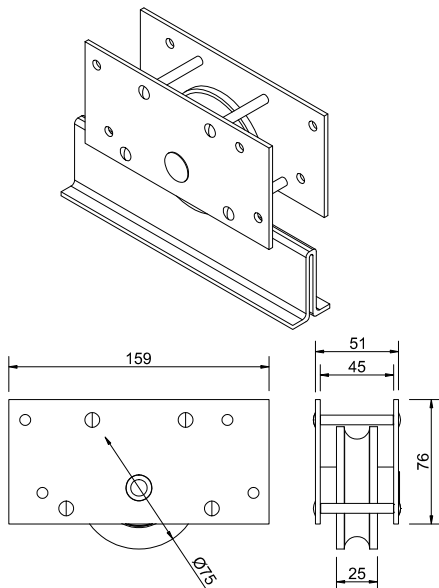

ONDERROL 5S

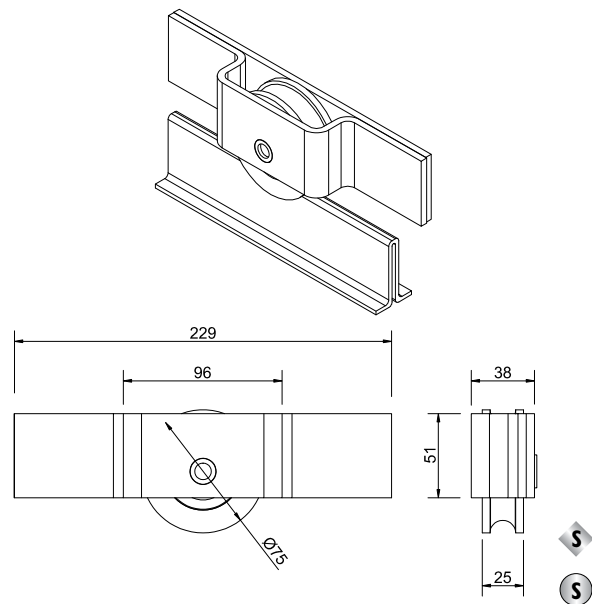

225

225 Sterling

onderlopend rechtschuivend beslag

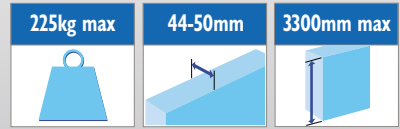

System opstelling: enkele rail

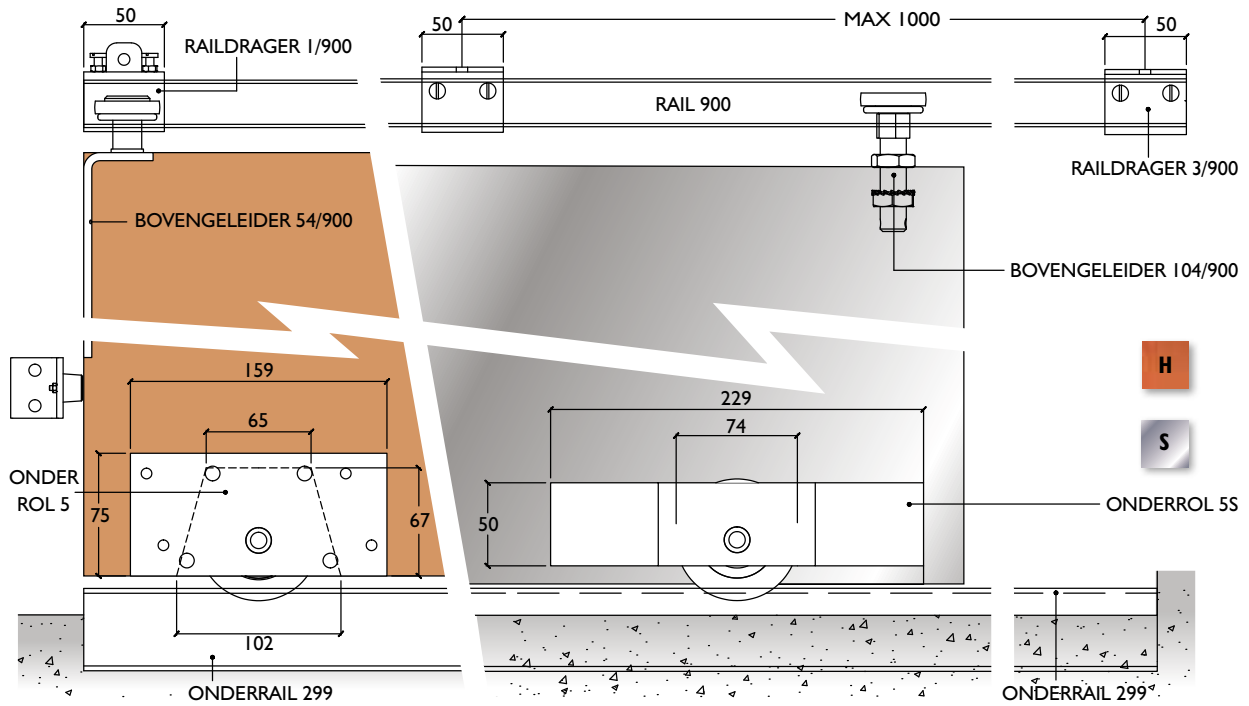

225

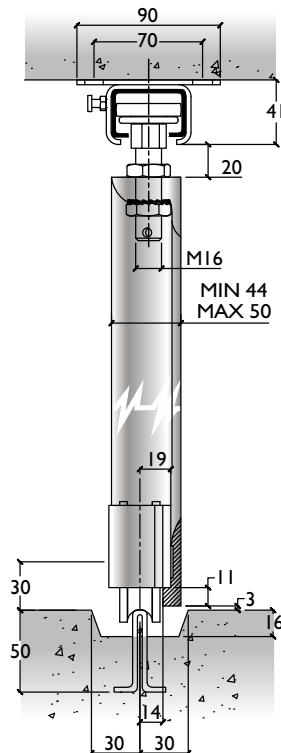
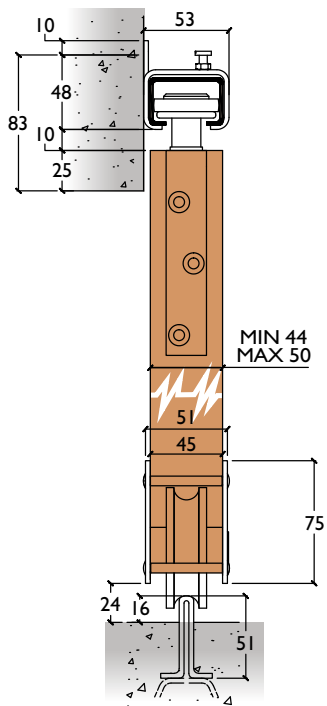
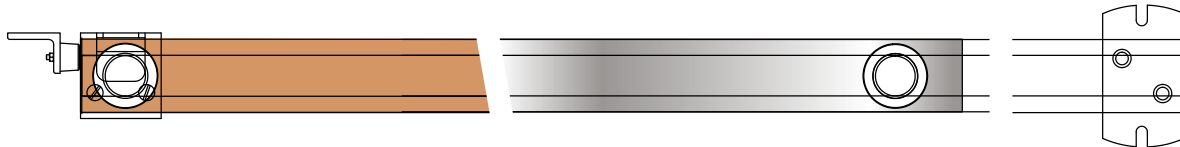

Opmerking:

Het gewicht van de deur(en) wordt door de vloer gedragen, zodat een lichte bovenconstructie mogelijk is.

Elk willekeurig aantal deuren kan worden toegepast op enkele of meervoudige railbanen.

De bovengeleiderail kan tegen de onderzijde van de bovendorpel van het kozijn worden gemonteerd, indien de deur in de dagopening schuift of tegen de zijwand als de deur geheel moet wegschuiven.

Hoge onderdorpels zijn noodzakelijk (minimaal 230mm) om de onderrollen te kunnen inbouwen.