

System 290

universele onderdelen

290

Rail:

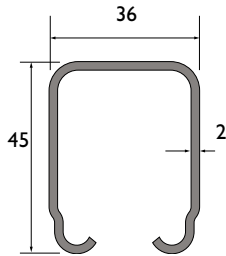

Model: 290

Materiaal: koudgewalst staal, gegalvaniseerd volgens sendzimir procédé.

Lengtes: 2000, 3000, 4000, 5000 en 6000mm.

Bevestigingsgaten: geen

Raildragers - wandbevestiging:

RAILDRAGER 1A/290

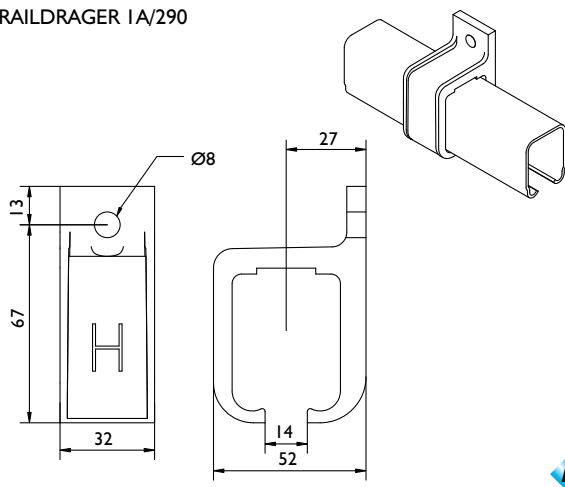

RAILDRAGER 1/290S
RAILDRAGER 1/290SLC
RAILDRAGER 1/290SRC

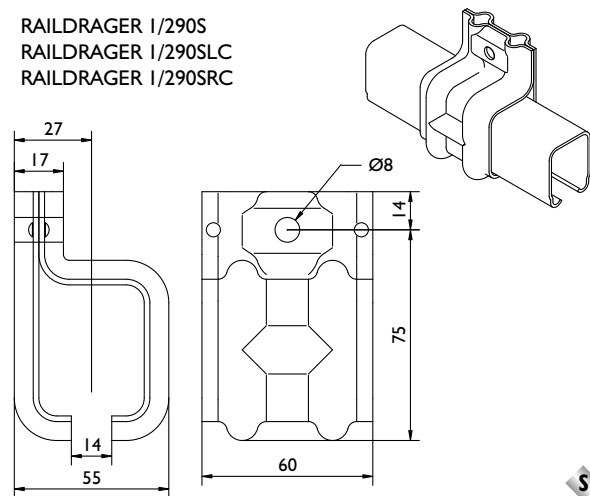

RAILDRAGER 9A/290

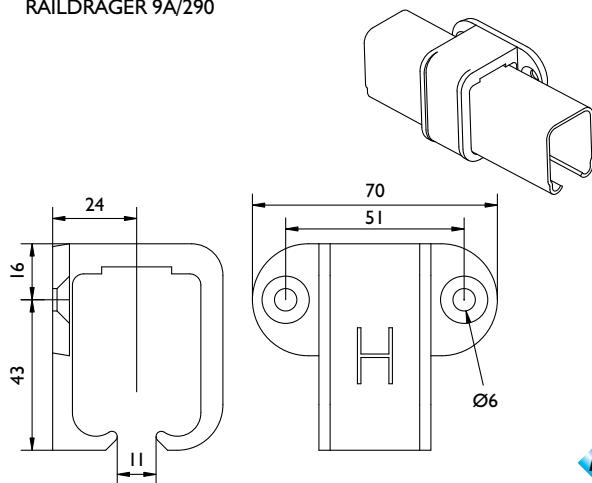

RAILDRAGER 5A/290

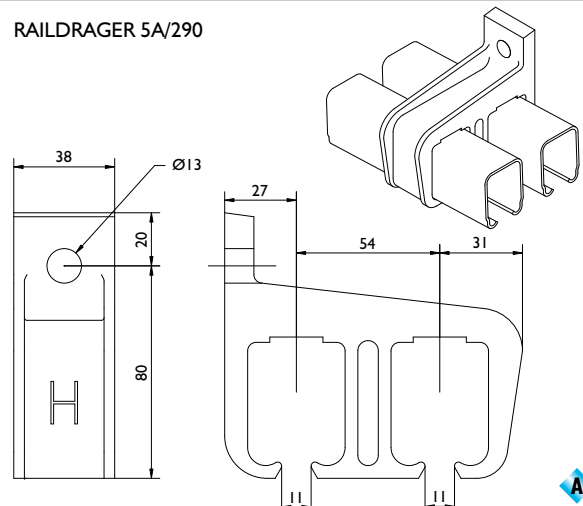

Legenda:

H = Houten deur	S = Staal
S = Stalen deur	A = Aluminium
MV = Metalen body	S = Stalen wielen
M = Messing geleidewielen	N = Nylon wielen

Opmerking:

Verbindings-raildragers worden aanbevolen op elke railverbinding, bij het specificeren de letter "X" toevoegen.

Toevoeging **C** = gesloten raildrager
Toevoeging **LC** = links gesloten raildrager
Toevoeging **RC** = rechts gesloten raildrager

Gesloten raildragers dienen aan beide einden van de totale railbaan te worden gemonteerd en dienen uitsluitend voor het afsluiten van de rail, niet als deurbuffer gebruiken.

System 290

universele onderdelen

Raildragers - plafondbevestiging:

RAILDRAGER 3A/290

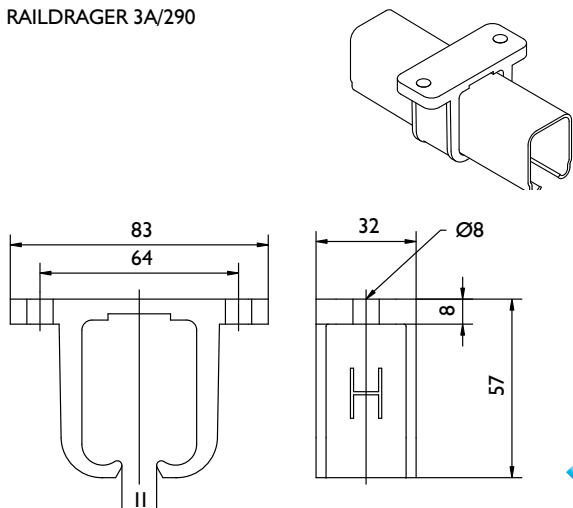

RAILDRAGER 4A/290

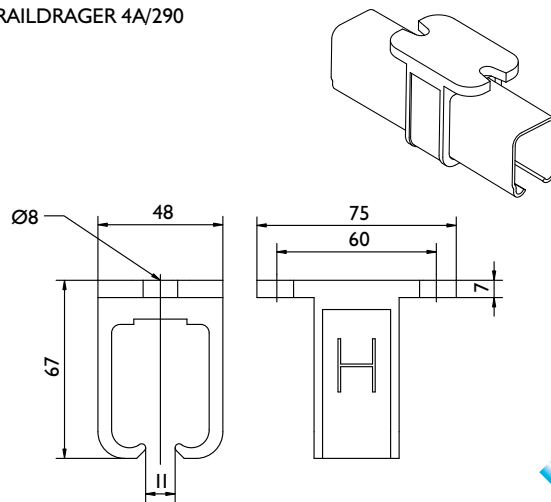

RAILDRAGER 4R/290S
RAILDRAGER 4R/290SC

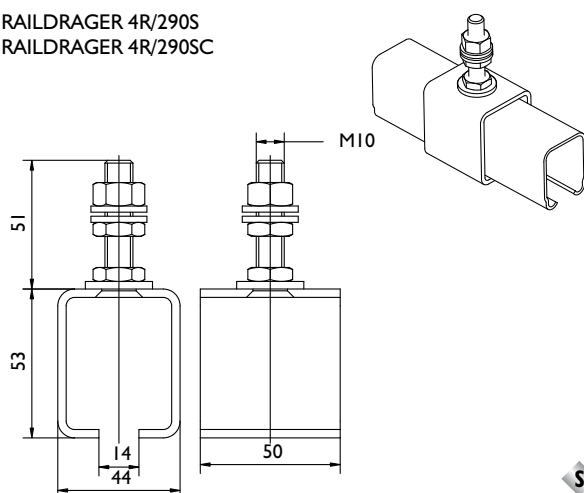

LASDRAGER 4R/290SB
LASDRAGER 4R/290SBC

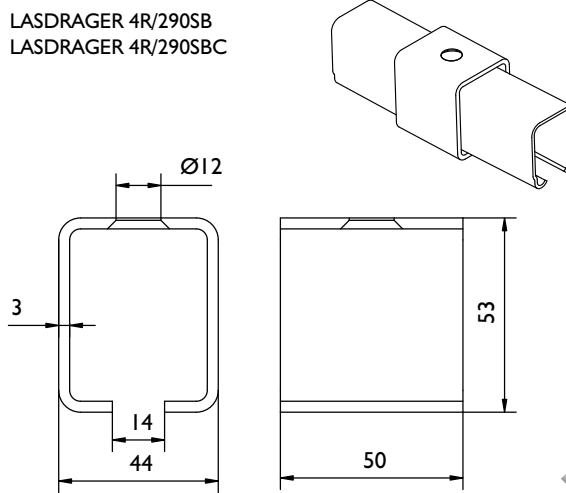

Specials:

EINDCLIP 1A/290EC

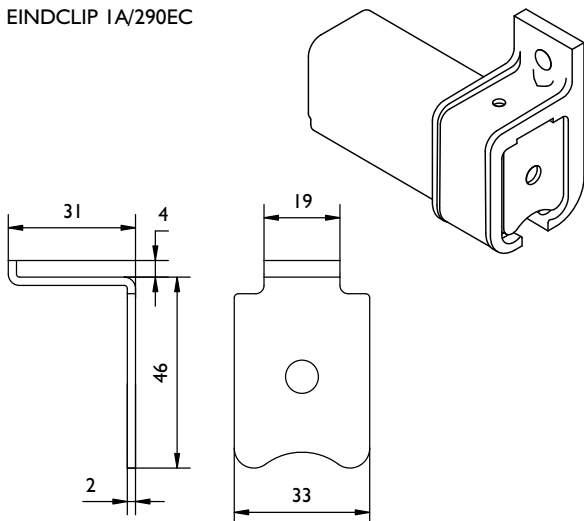

Eindclip ter afdichting en blokkering van de rail.
Bruikbaar i.c.m. raildrager: I, IA, 3A, 4A, 5A en 9A



STOP HH3/290

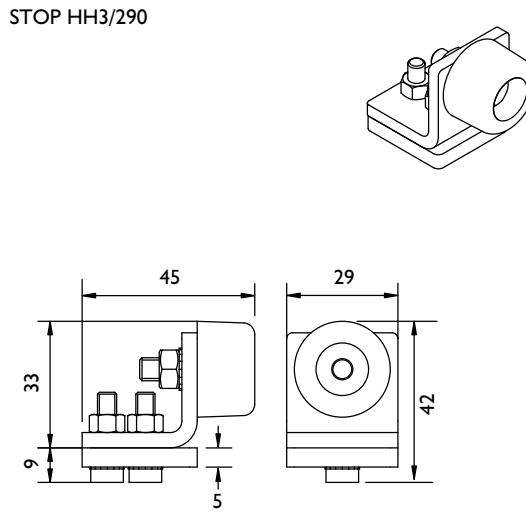

Voor bevestiging in de rail, staal gegalvaniseerd met stootbuffer.



System 290

tangent vouwdeurbeslag

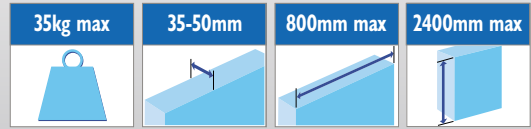

System opstelling:

290

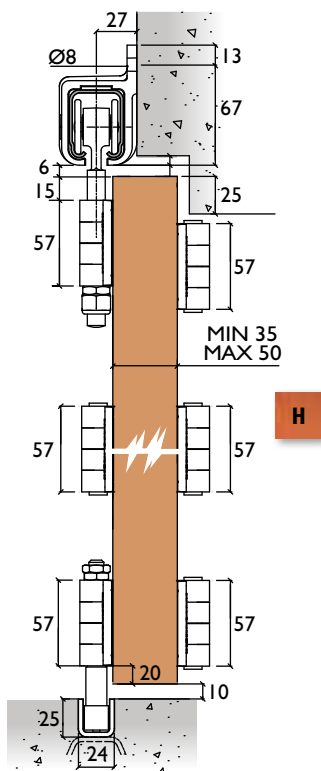
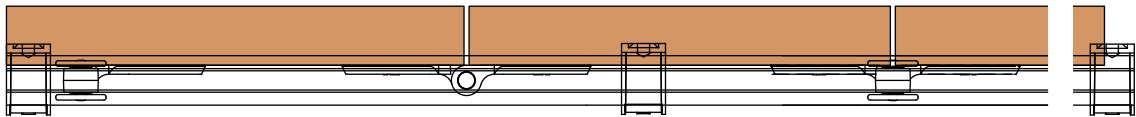
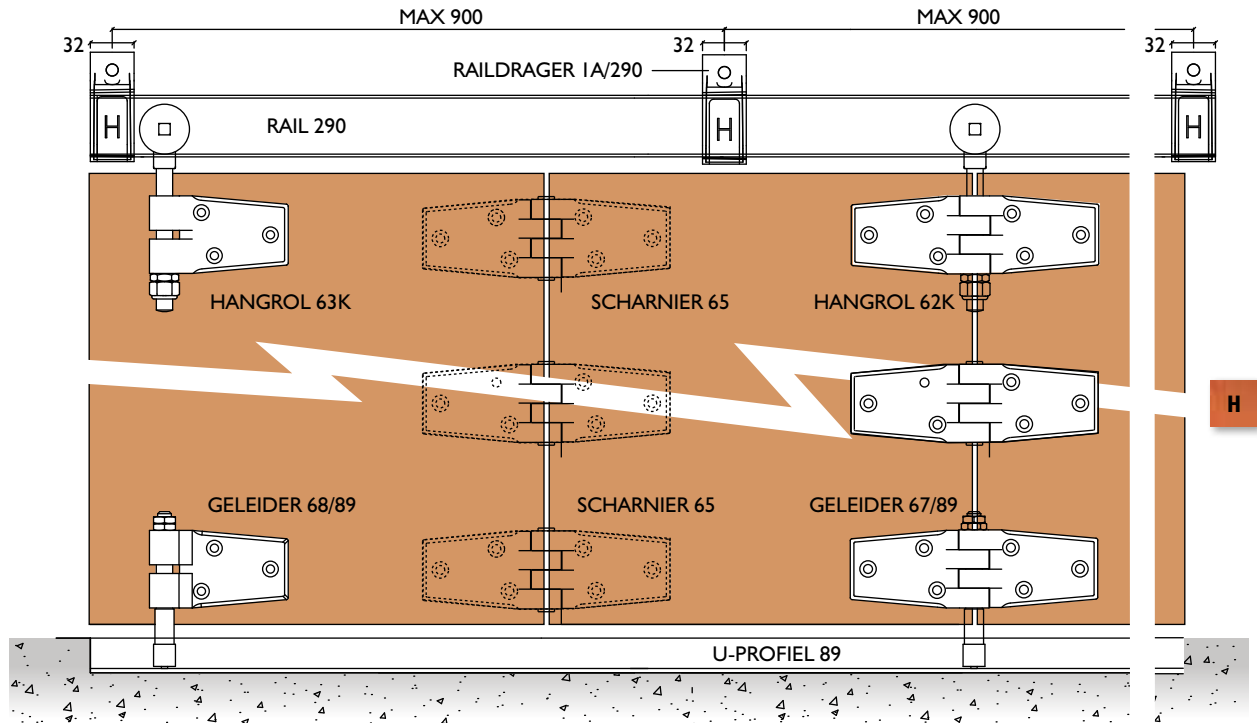

afgehangen met scharnier aan kozijnstijl

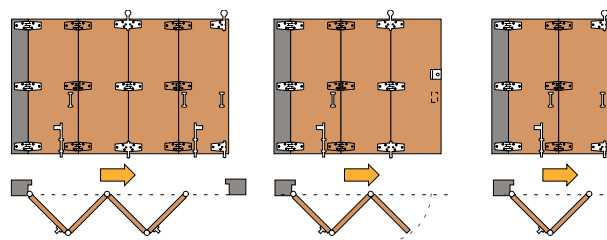

afgehangen met scharnier aan kozijnstijl

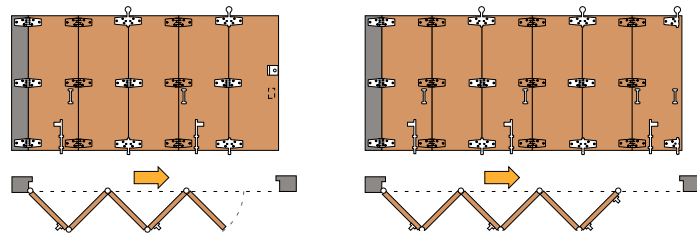

losschuivend

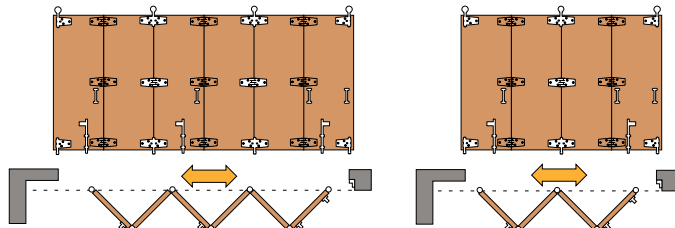

System 290

tangent vouwdeurbeslag

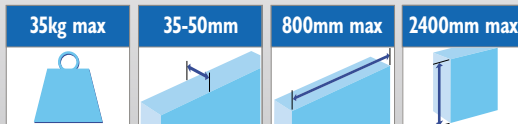

Hangrollen, geleiders en scharnieren:

HANGROL 62K

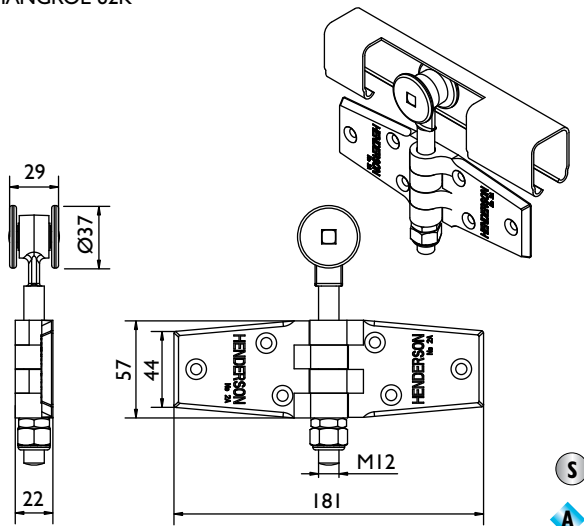

HANGROL 63K

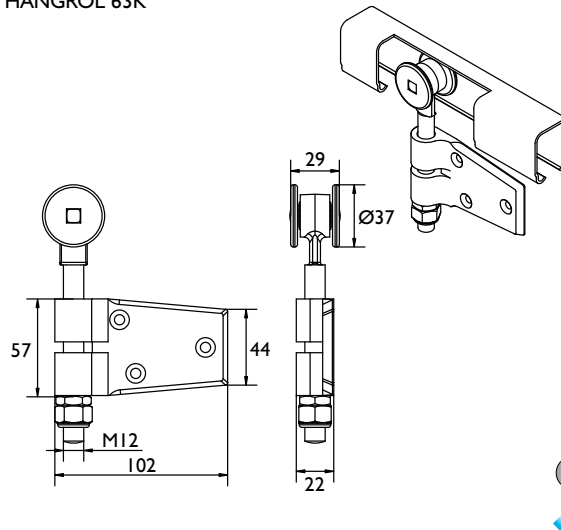

GELEIDER 67/89

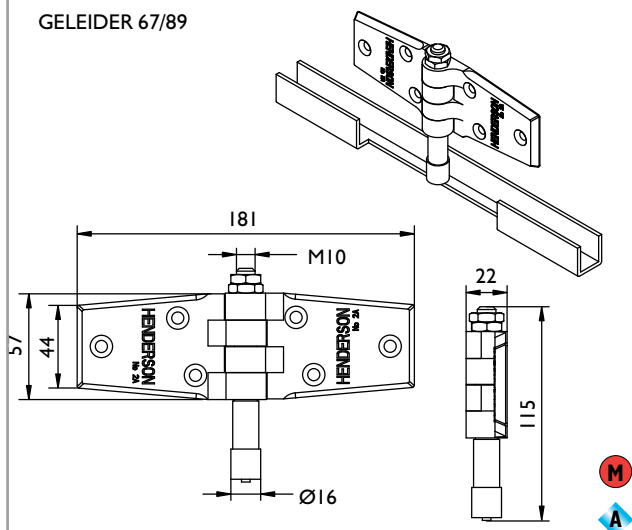

GELEIDER 68/89

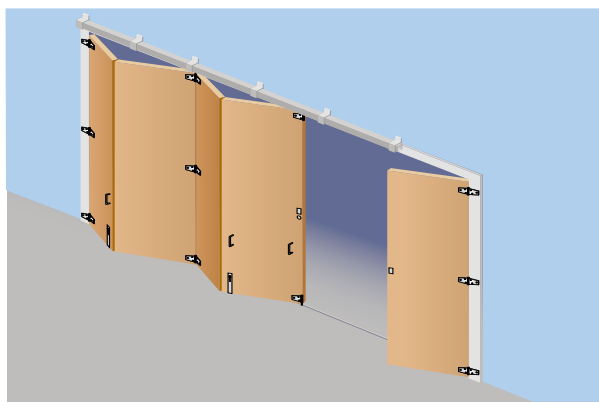
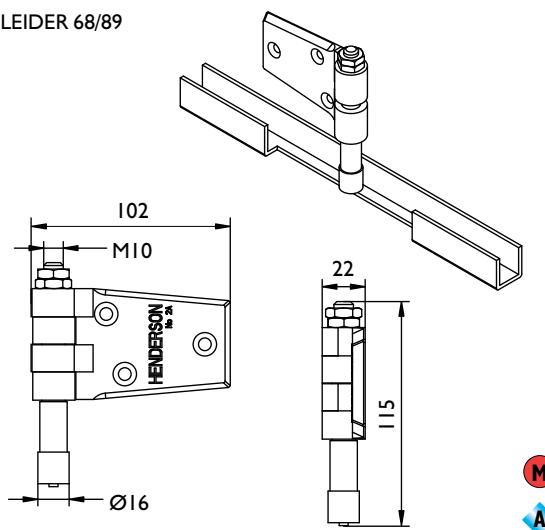

SCHARNIER 65

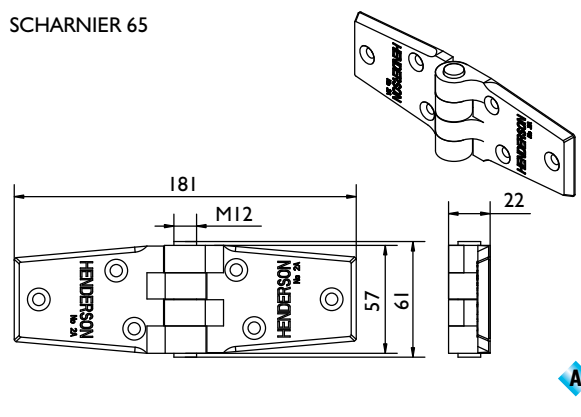

Opmerking:

H.o.h. afstanden scharnierpunten dienen gelijk te zijn!

Op de plaats waar het samengevouwen deurpakket hangt, moet een extra raildrager gemonteerd zijn.

Voor een soepele werking maximaal acht deurvleugels afhangen, alternatief kunnen losschuivende garnituren worden toegepast (minimaal 4 deurvleugels). Desgewenst kan van één van de deurvleugels, oneven aantal, een loopdeur worden gemaakt.

290