

zelfsluitende deuren in geval van brand, van volledig tot gedeeltelijk opengesloten deuren, kunnen ook normaal worden geopend en gesloten.

- NOTES:
 1. DRAWING IS FOR REFERENCE AND SUBJECT TO CHANGE WITHOUT NOTICE.
 2. APPLICATION IS OF SELF CLOSING DOOR WEIGHT MAX 360kg.
 3. ALL DIMENSIONS ARE IN MILLIMETER.

Description	30100 - ZELFSLUITEND / BRANDVEREND
PCH-code	30100-01
Doc-code	
Drawing-size	A0
Revision	A

HENDERSON
 Henderson
 Telephone : 0181 577345

Henderson

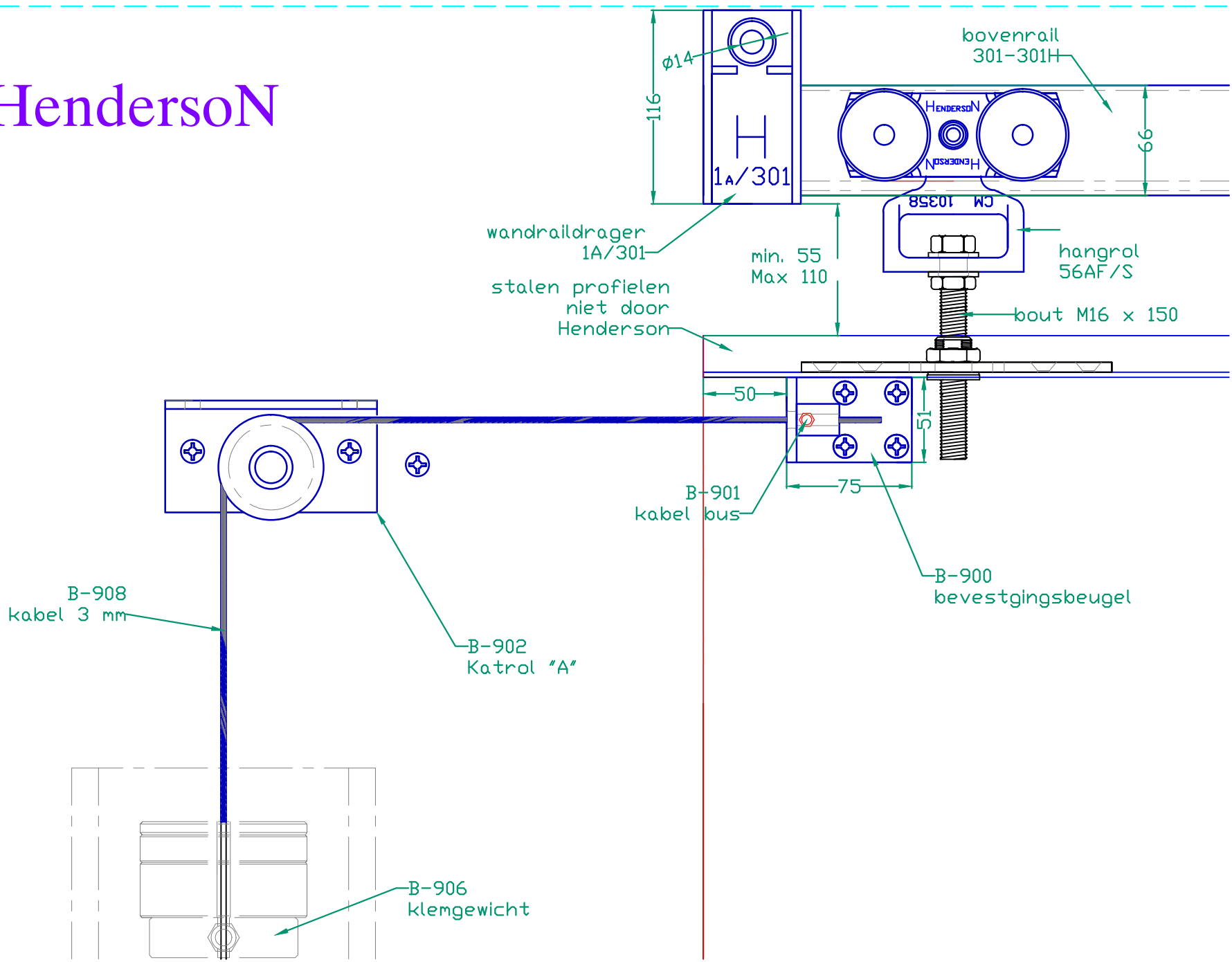

Henderson

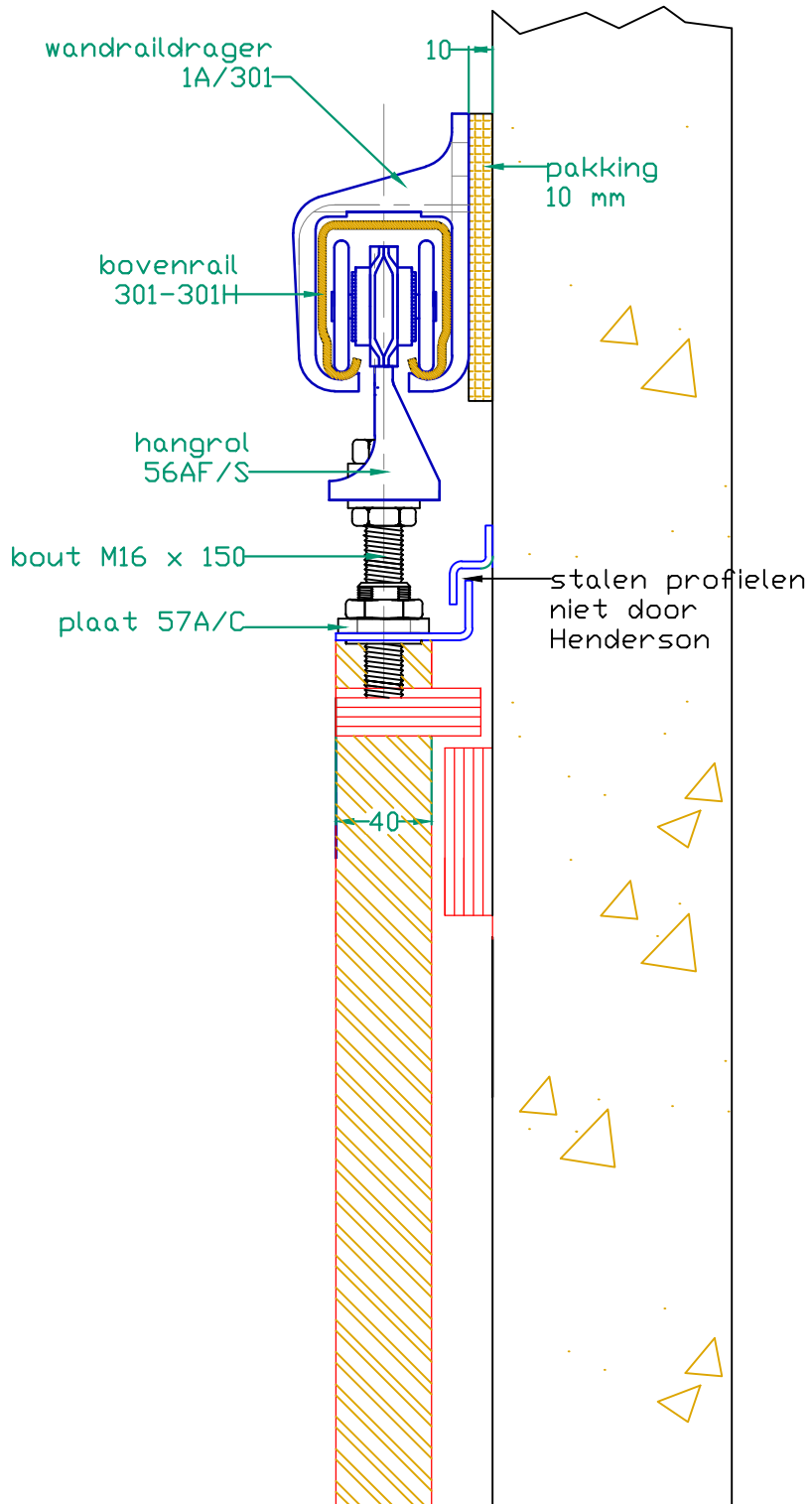

Henderson

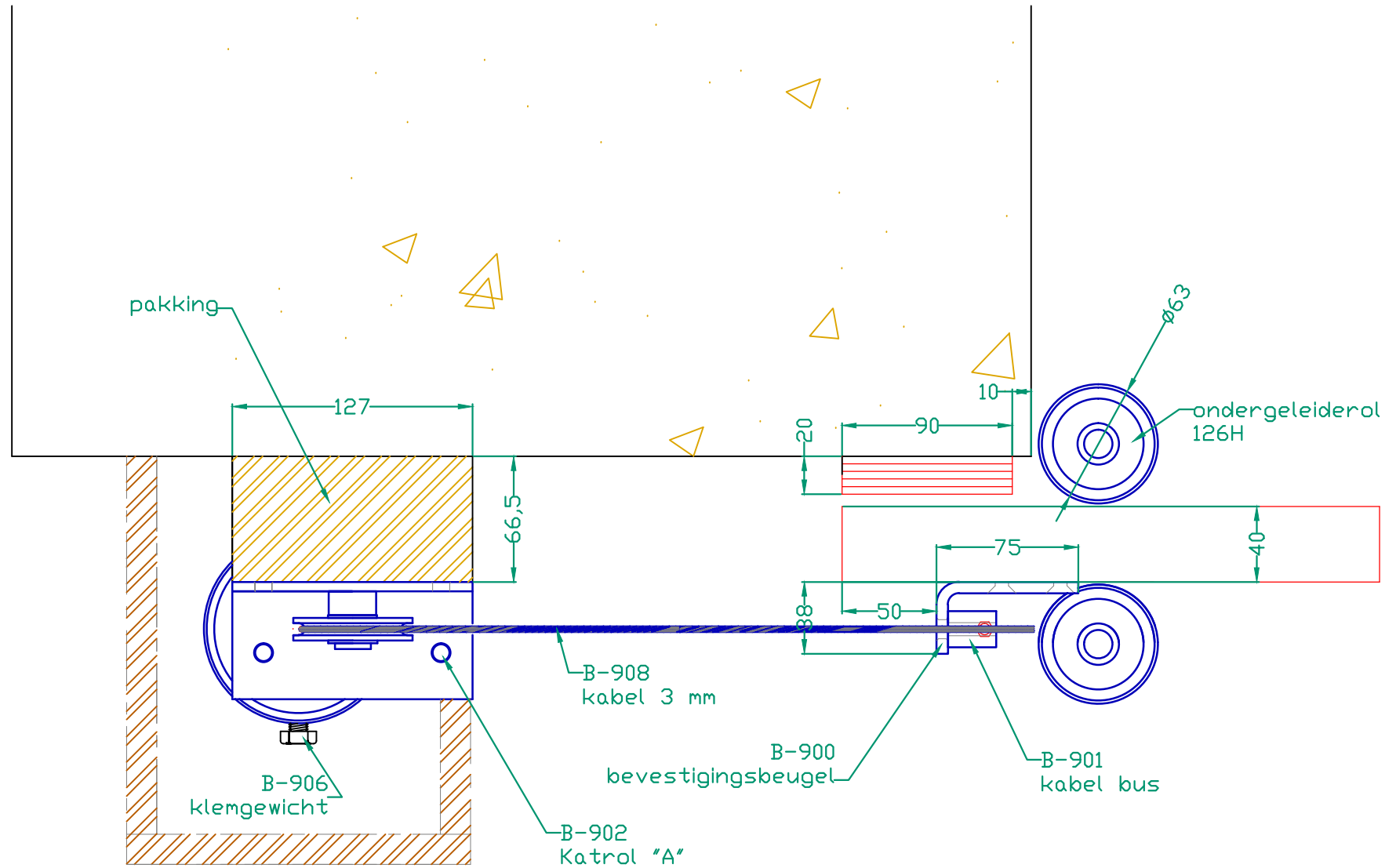

Henderson

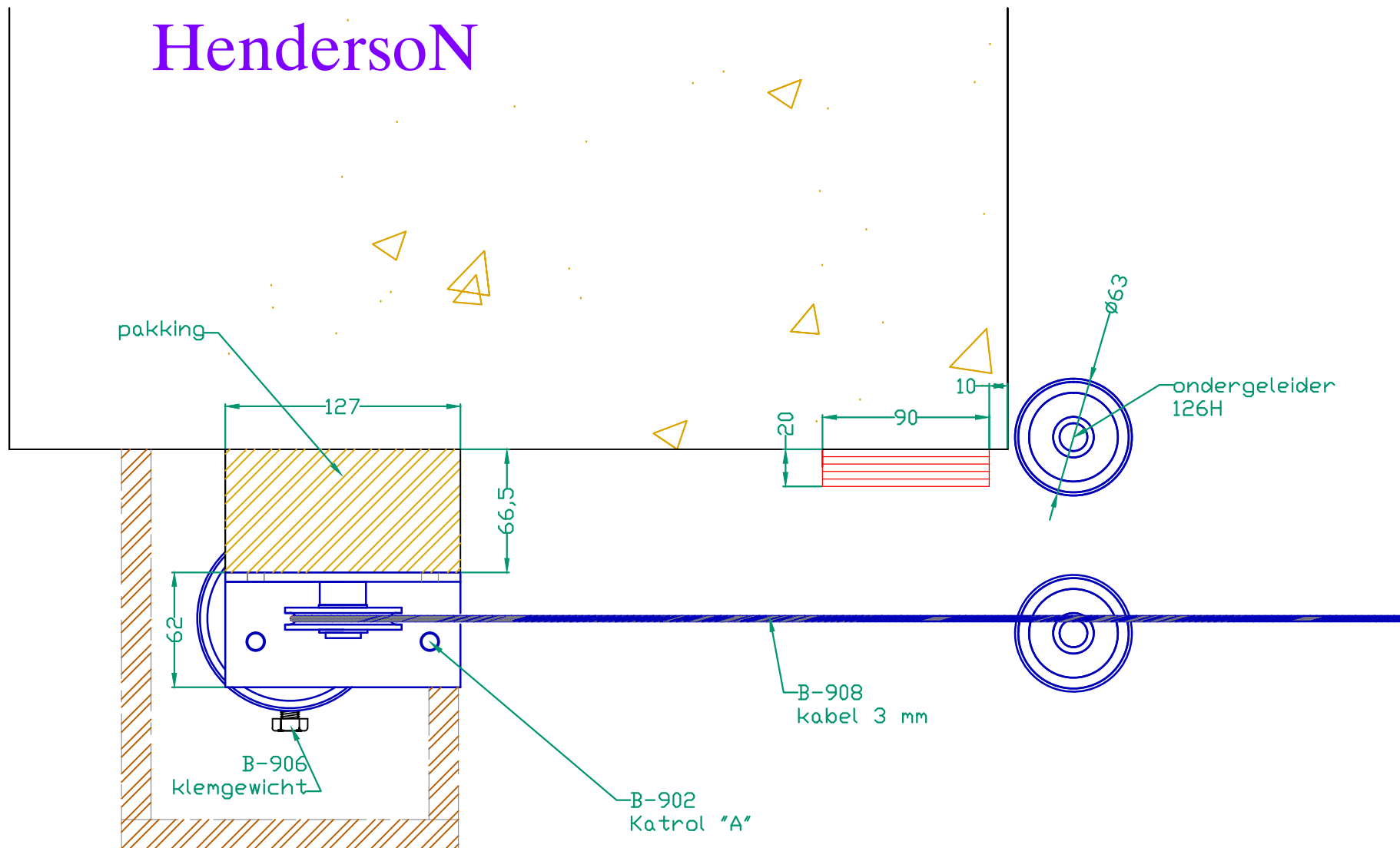

Henderson

