

FITTING INSTRUCTIONS - NOTICE DE POSE - MONTAGE HANDLEIDING - MONTAGEANLEITUNG ISTRUZIONI DI MONTAGGIO - INSTUCCIONES DE MONTAJE

Warranty. This product is covered by a 10 year manufacturer's warranty. Please see the P C Henderson website for terms and conditions.

WATCH THE INSTALLATION VIDEO

Visit: www.pchenderson.com/marathon-installation

Or scan the QR code using your phone

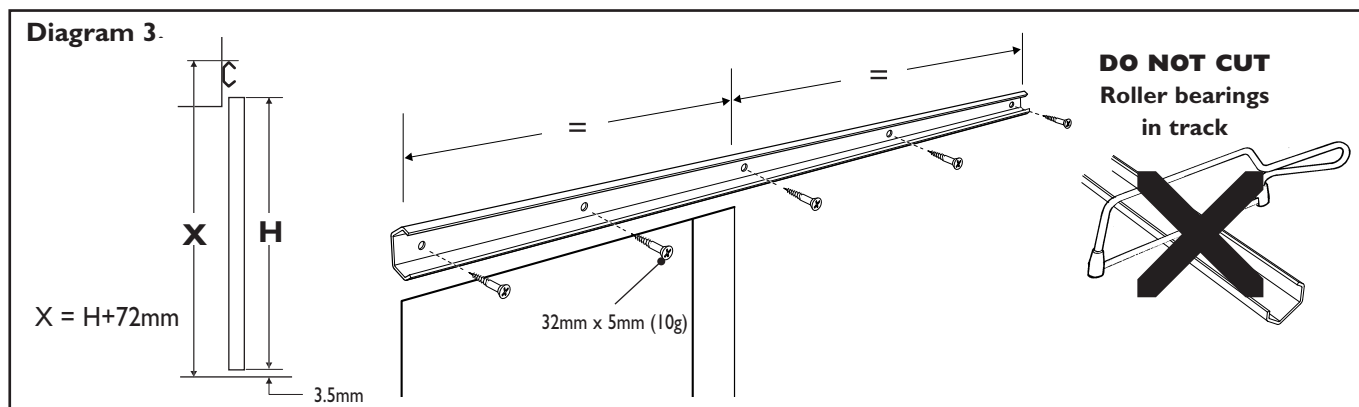
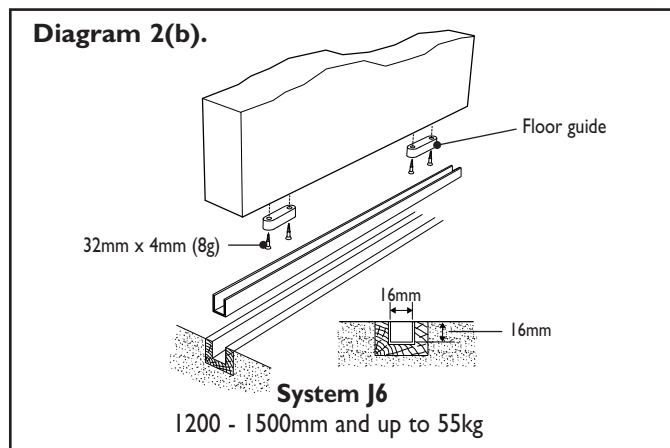
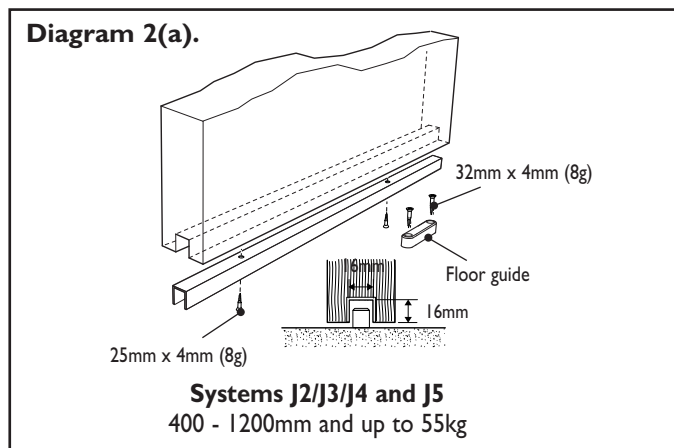
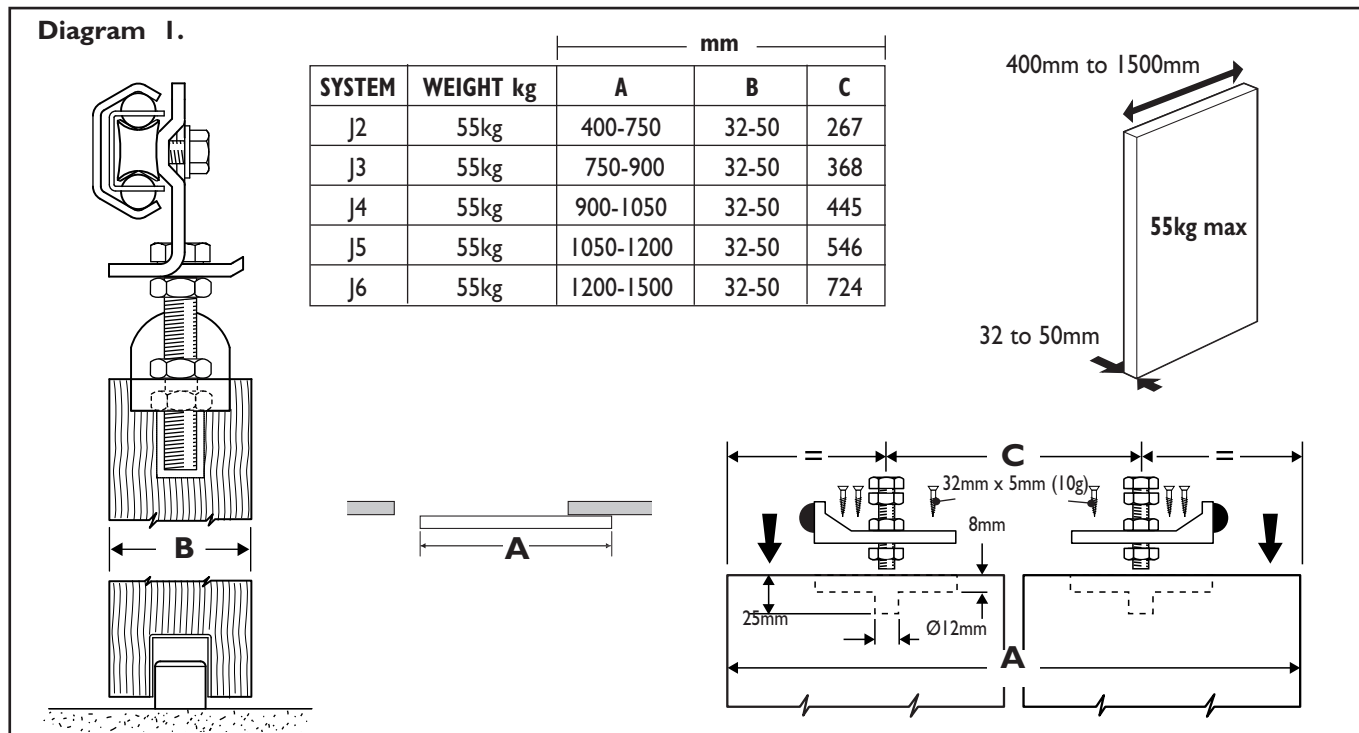

Diagram 4.

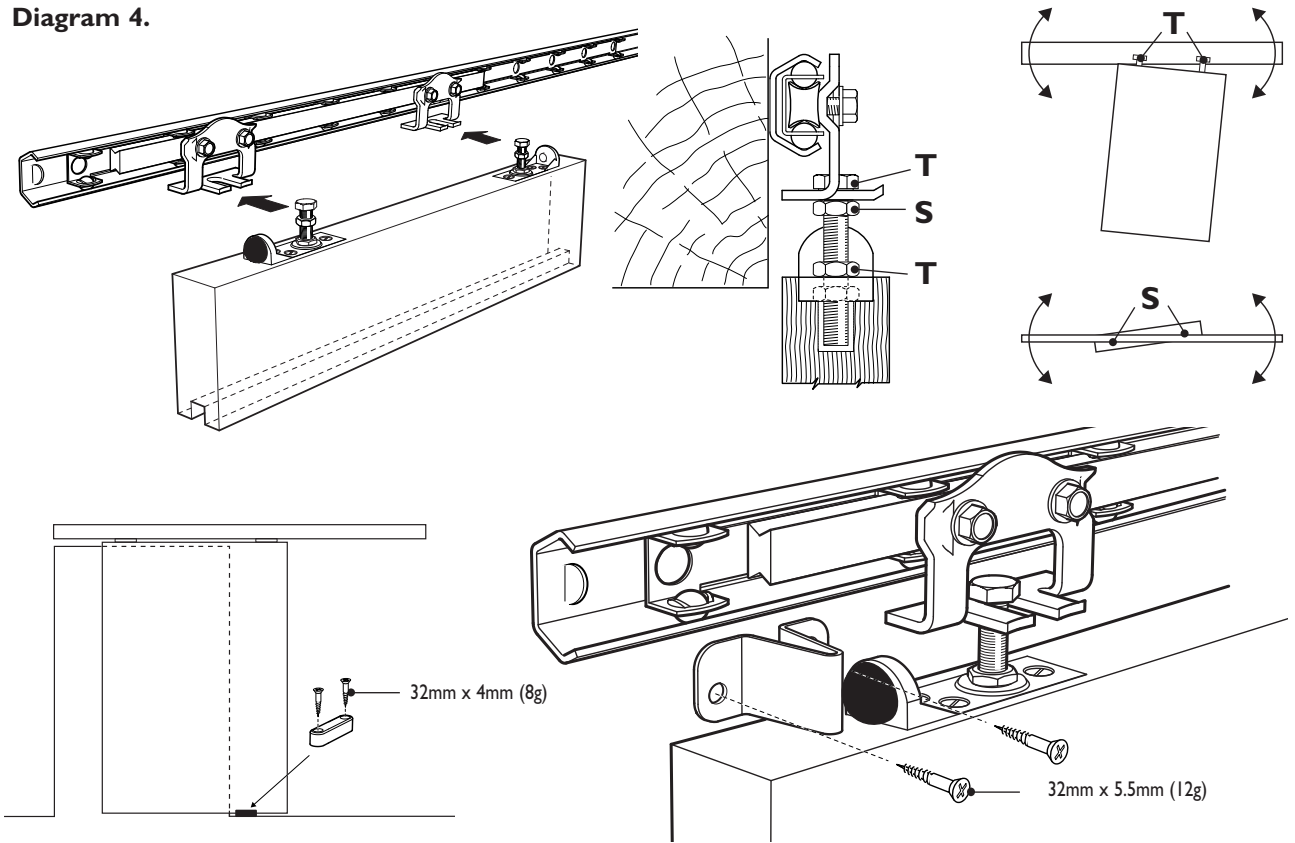
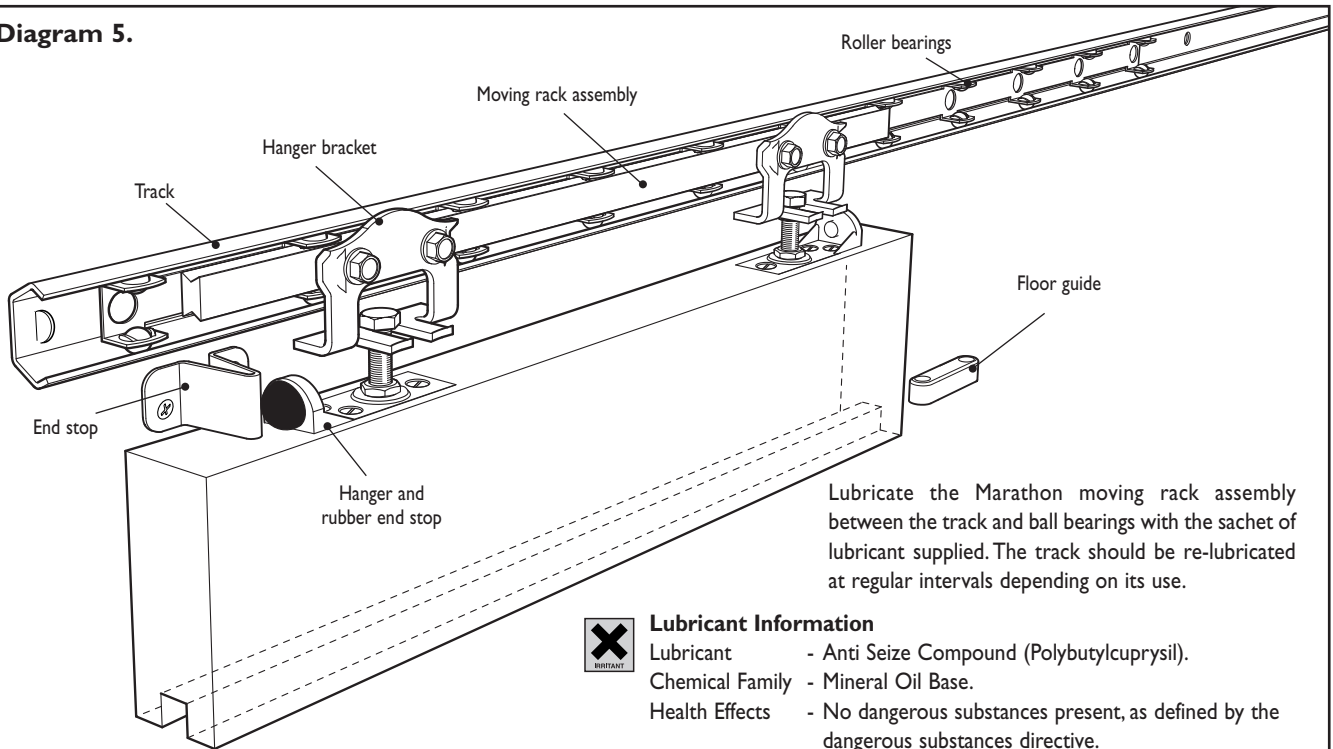

Diagram 5.



Lubricate the Marathon moving rack assembly between the track and ball bearings with the sachet of lubricant supplied. The track should be re-lubricated at regular intervals depending on its use.



Lubricant Information

- Lubricant - Anti Seize Compound (Polybutylcuprysil).
- Chemical Family - Mineral Oil Base.
- Health Effects - No dangerous substances present, as defined by the dangerous substances directive.
- First Aid - Eyes: Wash with water and consult medical practitioner.
- Skin: Wash with warm water and soap.
- Ingestion: Call medical practitioner immediately.



H411 Toxic to aquatic life with long lasting effects.
 P273 Avoid release to the environment.
 P391 Collect spillage.
 P501 Dispose of contents/container in accordance with local/regional/national/international regulations.

Please see website for Health & Safety datasheet.

