

System 30I & 30IH

universele onderdelen

30I

Rail:

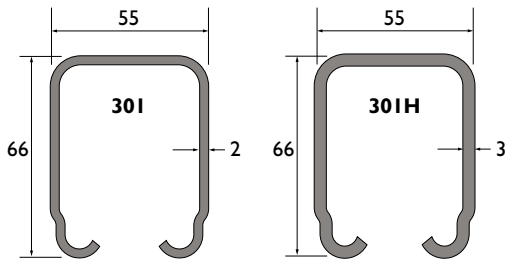

Model: 30I & 30IH

Materiaal: koudgewalst staal, gegalvaniseerd volgens sendzimir procédé.

Lengtes: 2000, 3000, 4000, 5000 en 6000mm

Bevestigingsgaten: geen

Raildragers - wandbevestiging:

RAILDRAGER 1A/30I

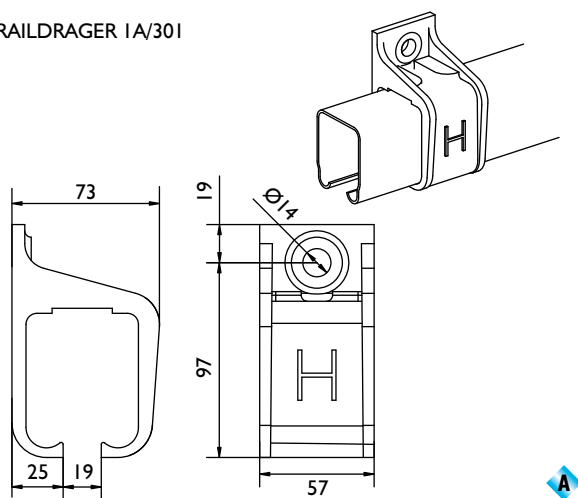

RAILDRAGER 1/30IS

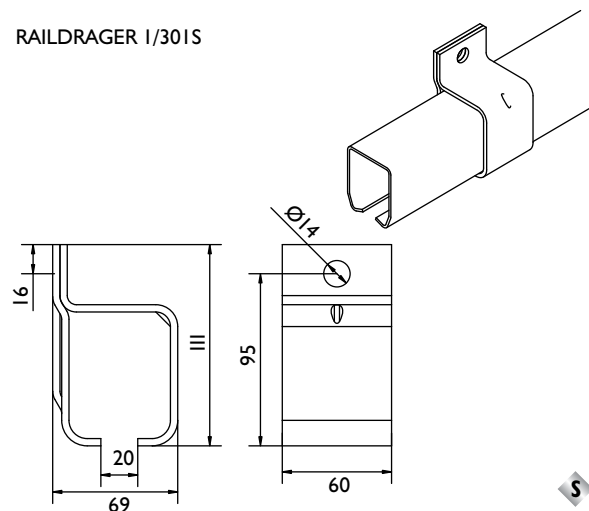

RAILDRAGER 9/30IS

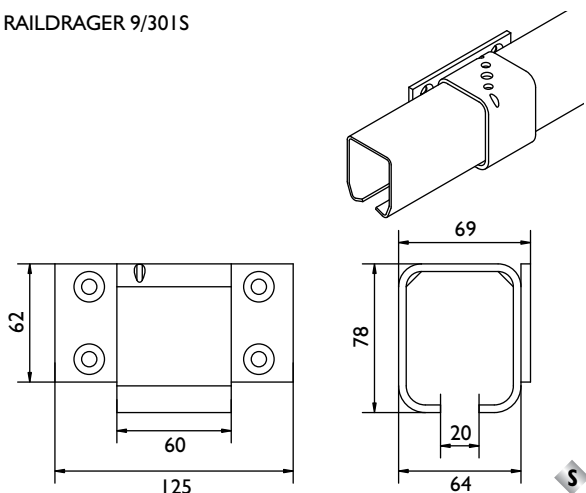

RAILDRAGER 5A/30I

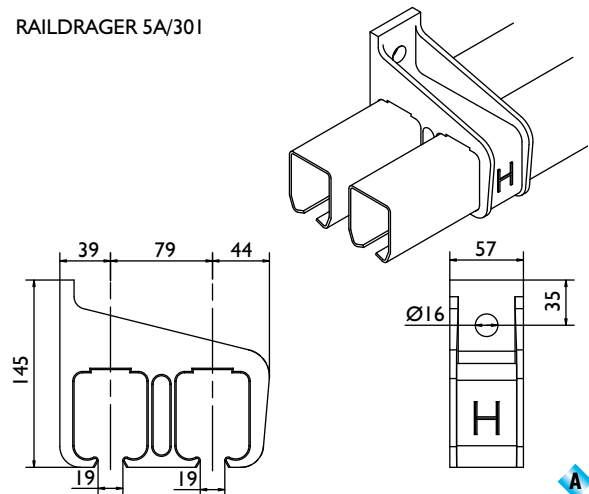

Legenda:

- | | |
|----------------------------------|--------------------------|
| H = Houten deur | S = Staal |
| S = Stalen deur | A = Aluminium |
| M = Messing geleidewielen | S = Stalen wielen |
| | N = Nylon wielen |

Opmerking:

Verbindings-raildragers worden aanbevolen op elke railverbinding, bij het specificeren de letter "X" toevoegen.

Toevoeging **C** = gesloten raildrager
 Toevoeging **LC** = links gesloten raildrager
 Toevoeging **RC** = rechts gesloten raildrager

Gesloten raildragers dienen aan beide einden van de totale railbaan te worden gemonteerd en dienen uitsluitend voor het afsluiten van de rail, niet als deurbuffer gebruiken.

System 30I & 30IH

universele onderdelen

Raildragers - wandbevestiging:

RAILDRAGER 5R/30IS

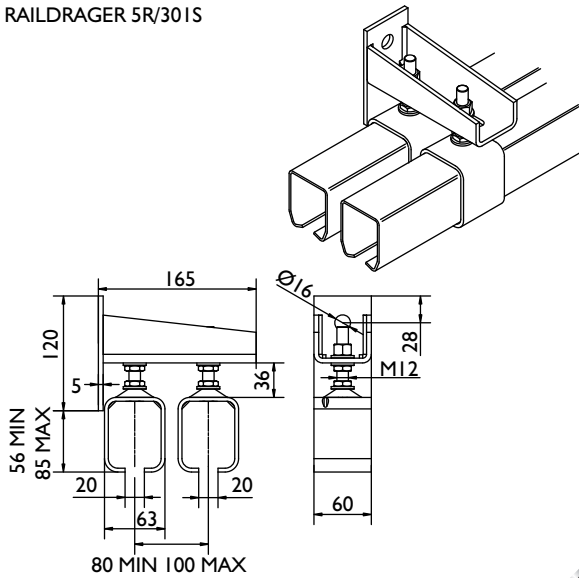

RAILDRAGER 7/30IS
RAILDRAGER 7/30ISLC
RAILDRAGER 7/30ISRC

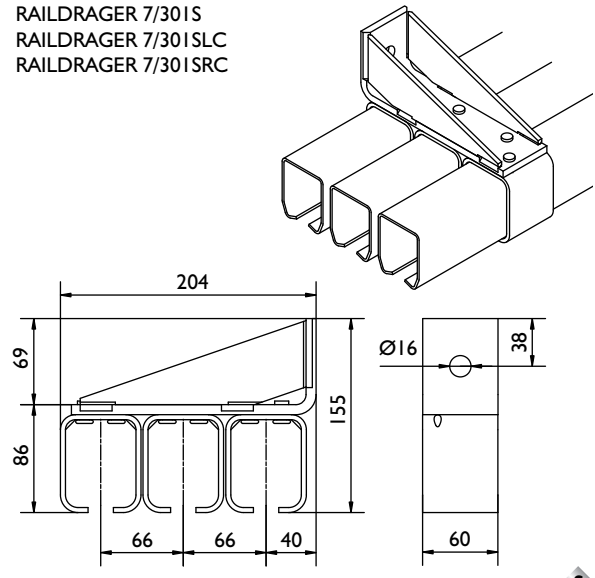

30I

Raildragers - plafondbevestiging:

RAILDRAGER 3A/30I

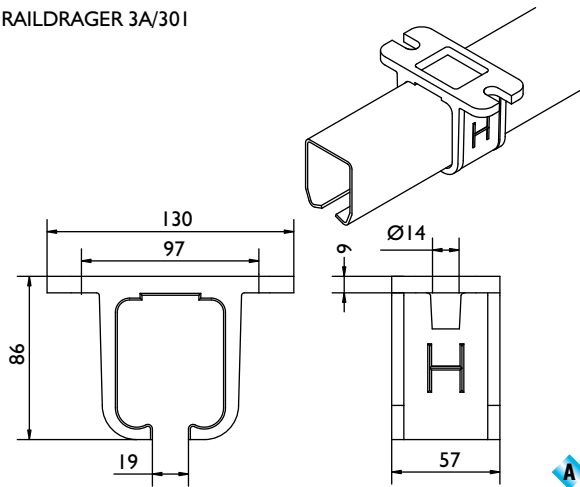

RAILDRAGER 4A/30I

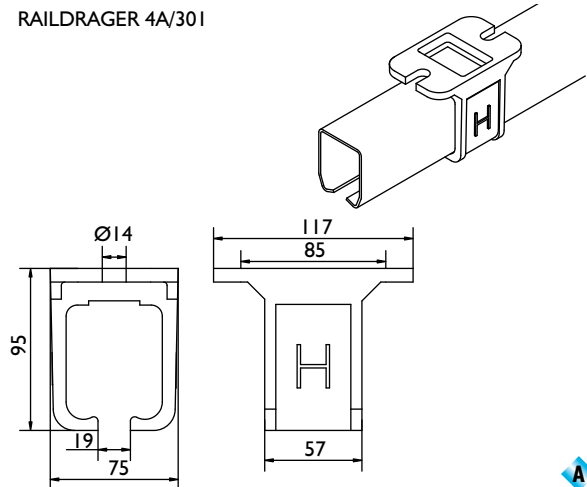

RAILDRAGER 4R/30IS
LASDRAGER 4R/30ISB

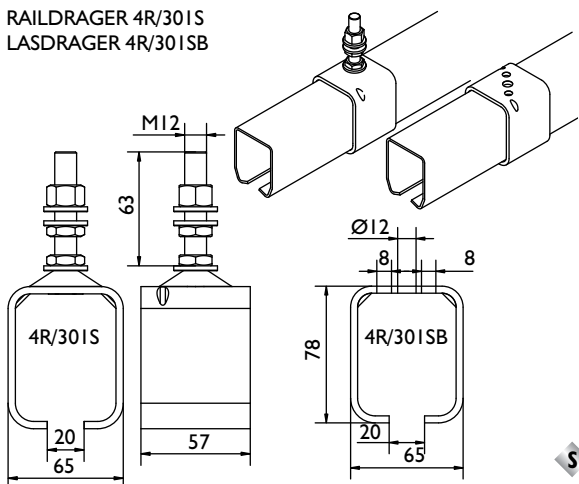

RAILDRAGER 3/30IS

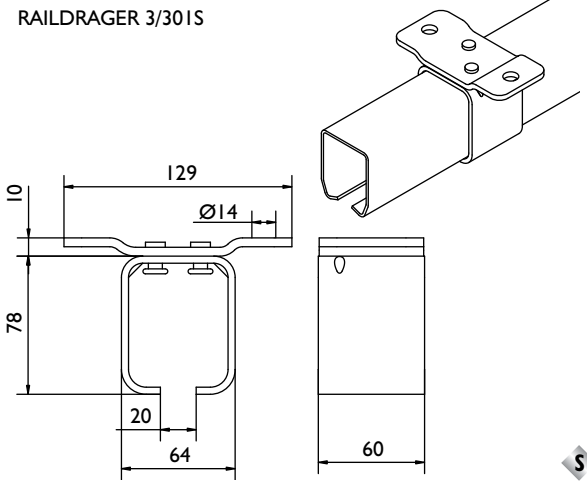

System 30I & 30IH

universele onderdelen

Raildragers - plafondbevestiging:

RAILDRAGER 4/30IS

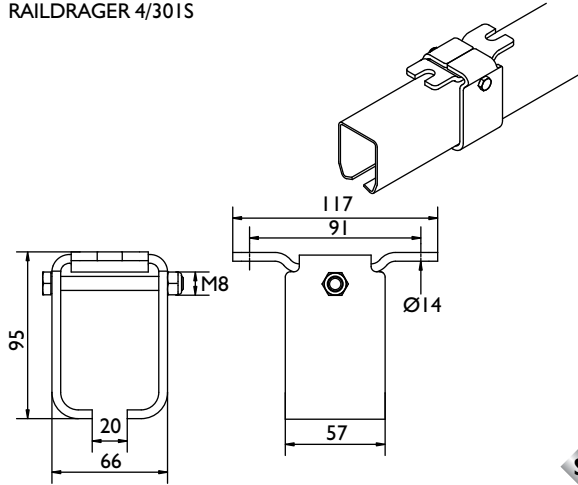

RAILDRAGER 6A/30I

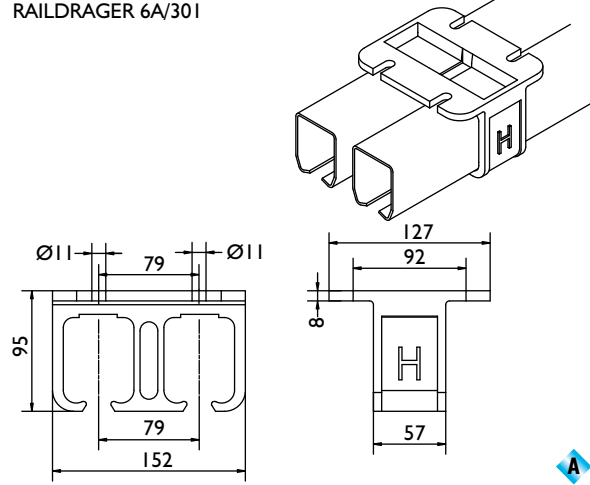

RAILDRAGER 8/30IS
RAILDRAGER 8/30ISC

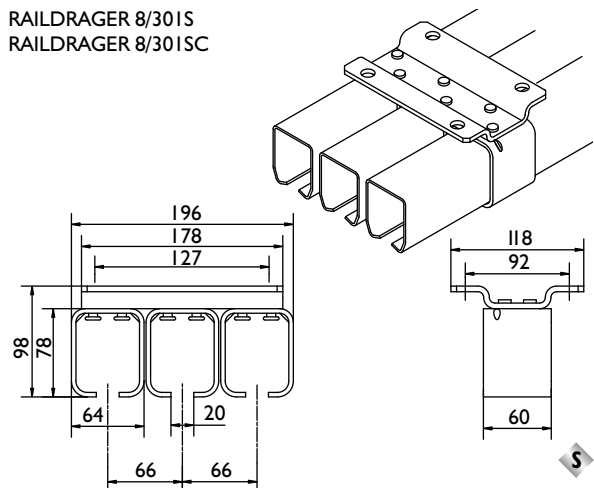

RAILDRAGER 4RX/30ITS

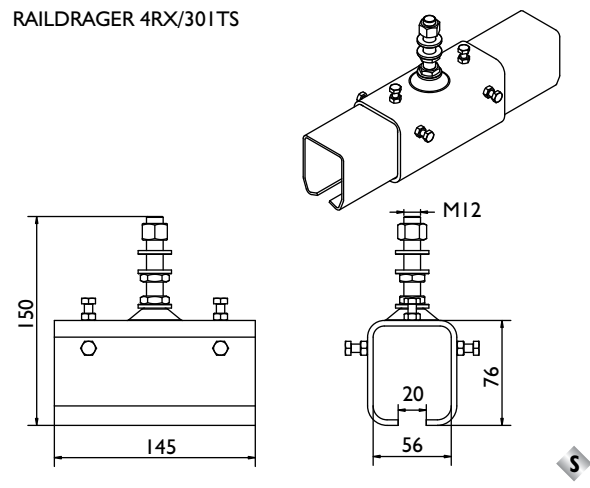

Specials:

EINDCLIP 1A/30IEC

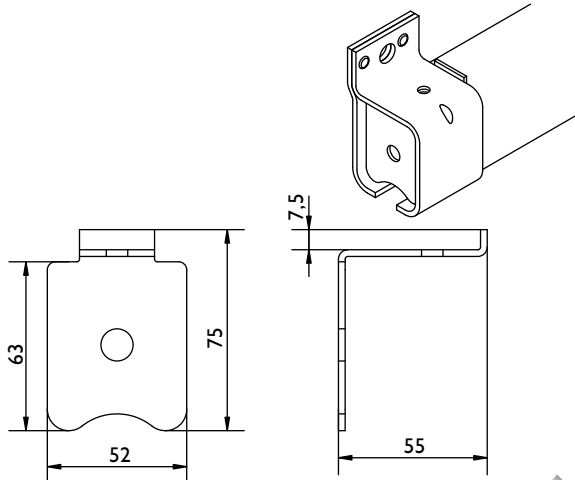

Eindclip ter afdichting en blokkering van de rail.
Bruikbaar i.c.m. raildrager: 1, 1A, 3A, 4A, 5A, 6 en 9A

STOP HH3/30I

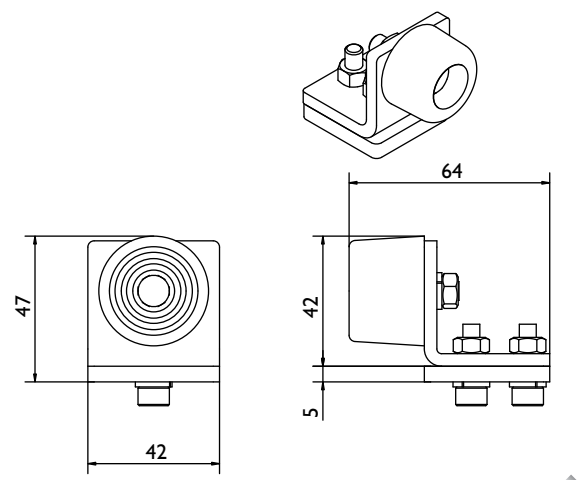

Voor bevestiging in de rail, staal gegalvaniseerd met
stootbuffer.

30I

System 30I & 30IH

council vouwdeurbeslag

System 30I	55kg max	45-55mm	900mm max	3300mm max
System 30IH	70kg max	45-55mm	900mm max	3600mm max

System opstelling:

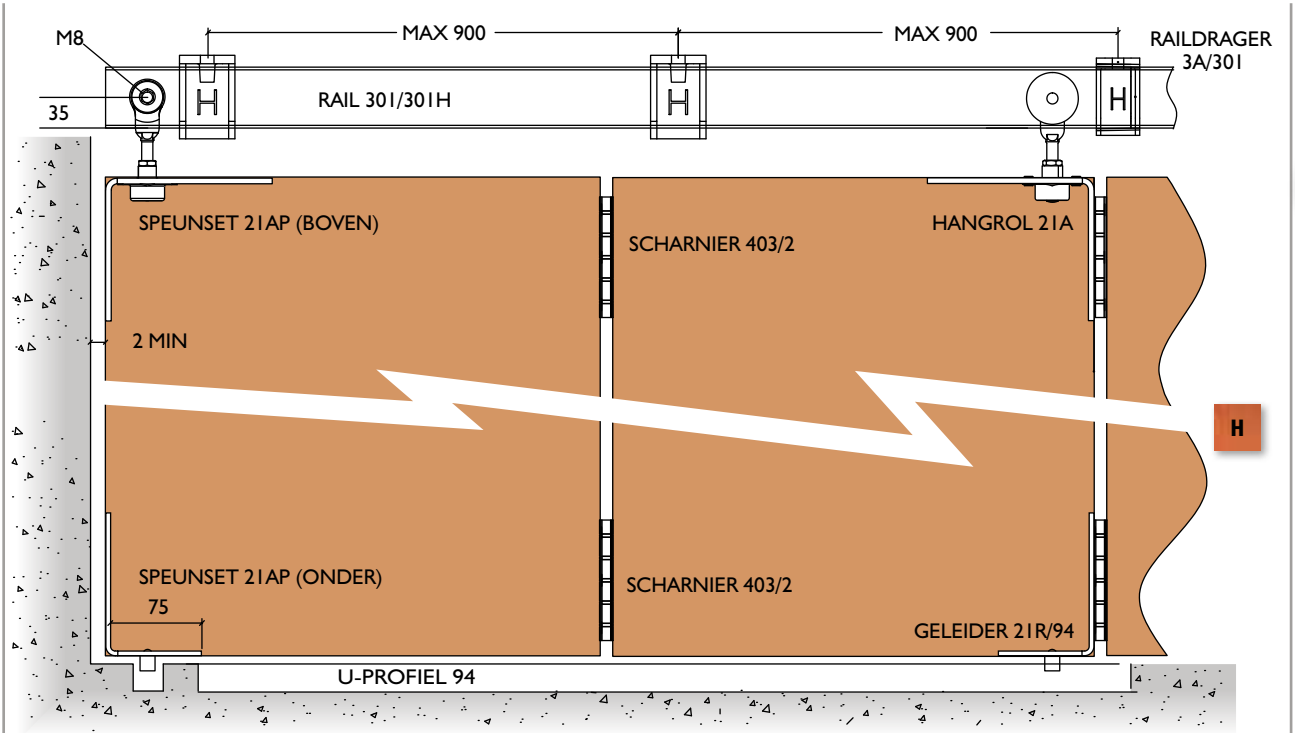

30I

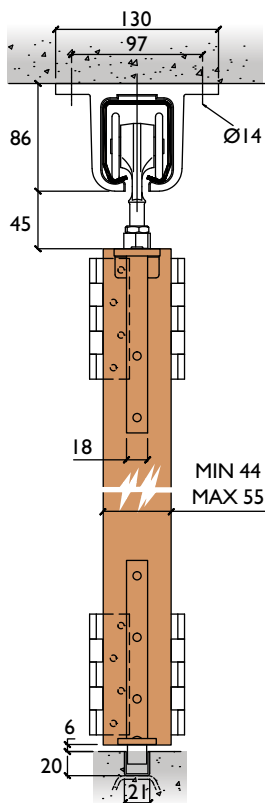
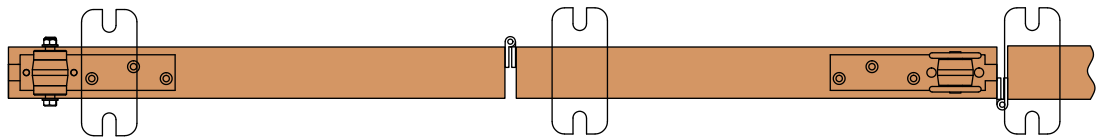

H

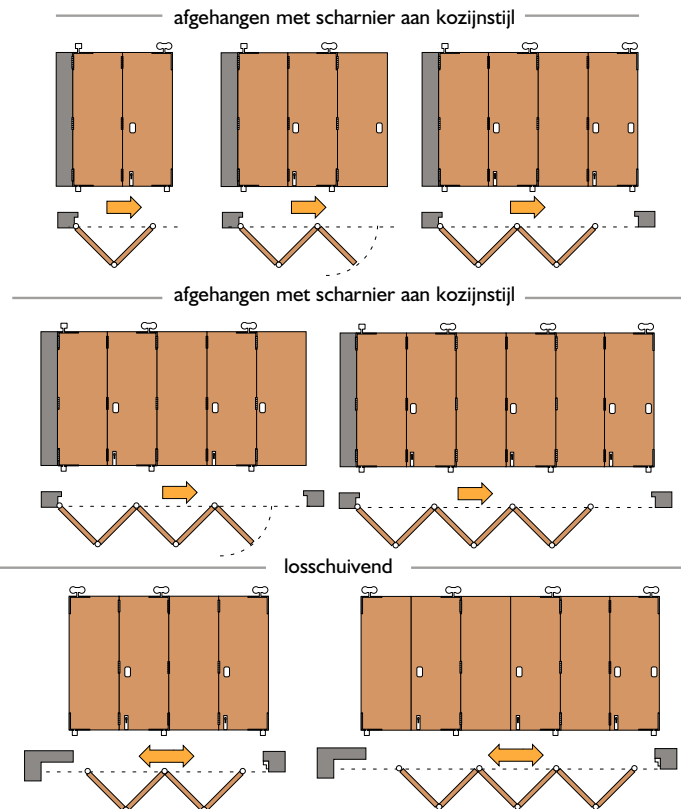

System 30I & 30IH

council vouwdeurbeslag

System 30I	55kg max	35-55mm	900mm max	3300mm max
System 30IH	70kg max	35-55mm	900mm max	3600mm max

Hangrollen, geleiders en scharnieren:

SPEUNSET 21A/P (BOVEN)

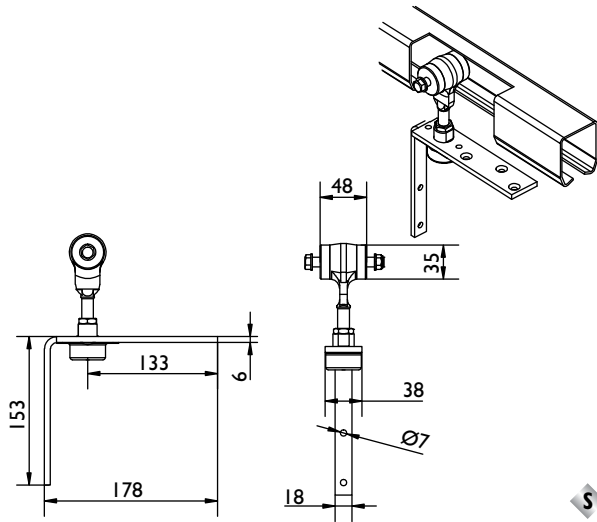

S

HANGER 21A
HANGROL 21A/4

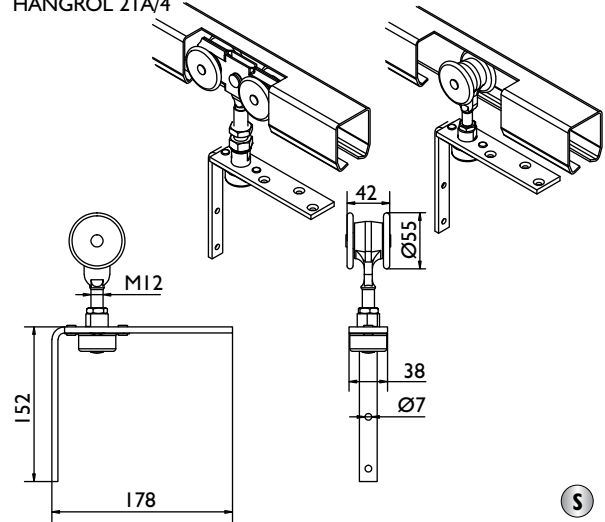

S

GELEIDER 21R/94
SPEUNSET 21A/P (ONDER)

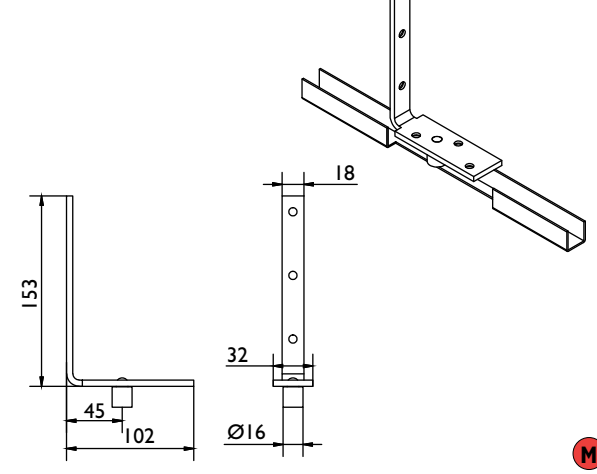

M

SCHARNIER 403/2

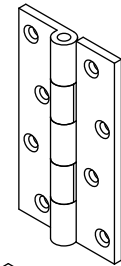
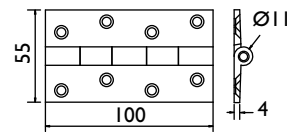

SCHARNIER 403/3

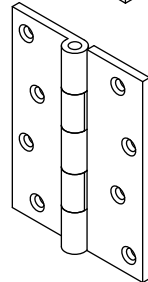
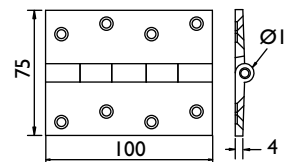

AG

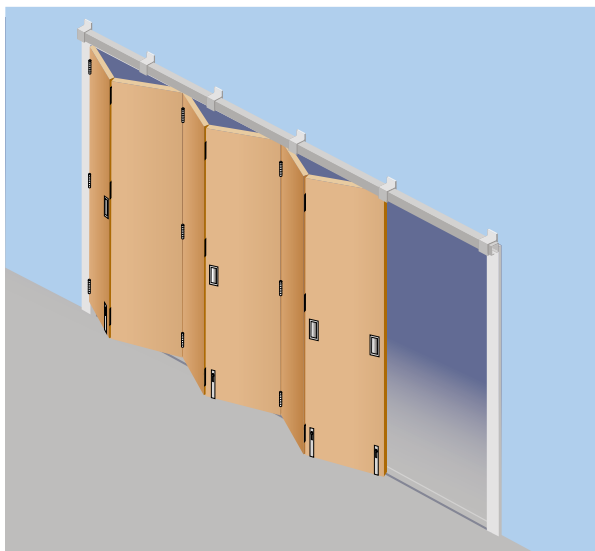

Opmerking:

Op de plaats waar het samengevouwen deuropakket hangt, moet een extra raildrager gemonteerd zijn.

Voor een soepele werking maximaal acht deurvleugels afhangen, alternatief kunnen losschuivende garnituren worden toegepast (minimaal 4 deurvleugels).

Desgewenst kan van één van de deurvleugels, oneven aantal, een loopdeur worden gemaakt (tot 3000mm deursoort). Gebruik een 4-wielige hangrol bij een draaideur.

Bij gebruik van speunset 21A/P zijn alle deurvleugels gelijk; afgehangen aan het kozijn dan is de eerste deurvleugel smaller, namelijk deurbreedte - (45 + 1/2 deurdikte).

H.o.h. afstanden scharnierpunten dienen gelijk te zijn!